

MC10

USER MANUAL

CONTENTS

1 SAFETY GUIDE	01
2 DIMENSIONS	03
3. OVERVIEW	04
4 LITHING PARAMETERS	05
4.1 Technical parameters	05
4.2 COLOR, GOBO, ANIMATION	07
4.3 PHOTOMETRICS	12
5 LIGHTING SETTINGS.....	13
5.1 Menu.....	13
6. INSTALLATION	15
6.1 Installation instructions and precautions.....	15
6.2 POWER CONNECTION	17
6.3 SIGNAL CONNECTION	18
6.4 DMX Chart	20
7 Errors	24
8 TROUBLESHOOTING	25
9 MAINTENANCE AND CARE	26
10 EXPLODED VIEW OF THE LAMP STRUCTURE.....	27

1 SAFETY GUIDE



The products are packed in good condition when leaving factory. Please operate according to the user manual. Machine failure caused by human factors is not covered by the warranty.



When electrical equipment is in operation, be careful of electric shock and do not touch it!



Do not look directly at the light source to avoid damage to your eyes.



To protect environment, please dispose of/recycle the product according to local regulations at the end of its life.



NOTE: Replace any screen that is cracked.



The shortest distance from the object to be illuminated is 5 meters.

- The light source in this luminaire shall be replaced by the manufacturer, its service agent or a similarly qualified person. If the external flexible cable or cord of this luminaire is damaged, the cord shall be replaced by a qualified person of the manufacturer or its service agent to avoid a hazard.
- After receiving the lamp, please check whether there is any damage caused by transportation. If there is any damage, do not use the lamp and contact the supplier or manufacturer immediately.
- The lamp should be installed in a well-ventilated place, at least 50cm away from the wall, and check whether the ventilation holes are unobstructed.
- Please do not open the lamp to repair it yourself.
- Electrical connections must be made by qualified installers.
- Each lamp should be safely grounded and the electrical installation should be carried out in accordance with relevant standards.
- Do not use a power cord with damaged insulation, and do not place the power cord on other wires. When the lamp is not in use or is being cleaned, unplug the power cord. Do not unplug or pull the power cord forcefully or directly.
- After working at full power for 10 minutes, the surface temperature of the lamp is about 40 degrees. After stable operation, the surface temperature of the lamp should be around 70 degrees.
- There are no user-serviceable parts inside this lamp. Before operating the lamp, please check that all parts are well connected and the screws are secure.
- If you have any questions, please contact the supplier or manufacturer in time.

● Direct sunlight or any other strong light source that penetrates the front lens of lamp can cause serious internal damage. Do not expose the front lens of lamp to direct sunlight or any other strong light source at any angle during unpacking, installation, use, or when it is idle outdoors for an extended period of time. Do not aim beam of one lamp directly at another.

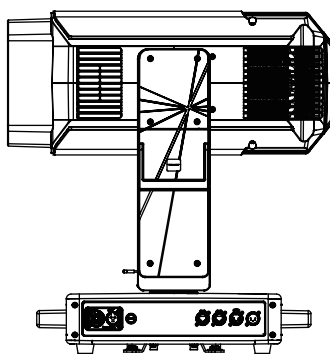
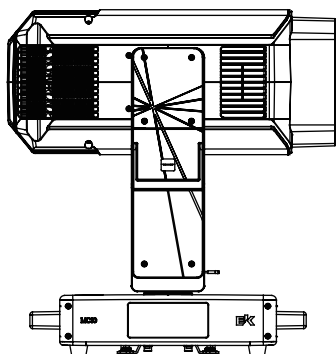
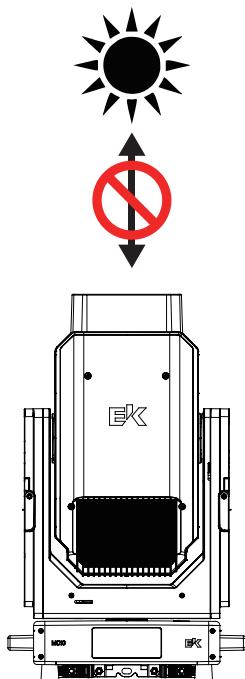

2 DIMENSIONS

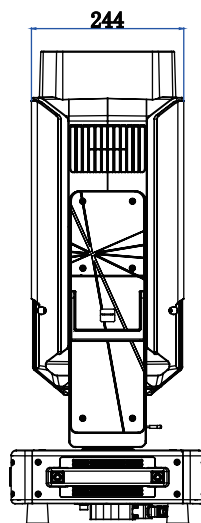
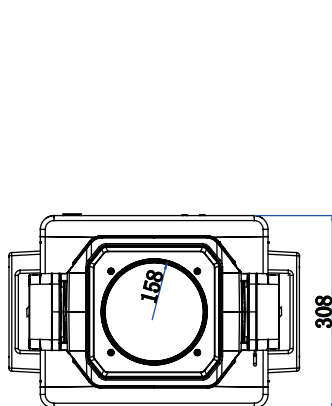
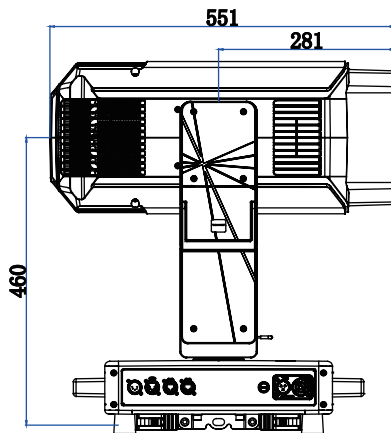
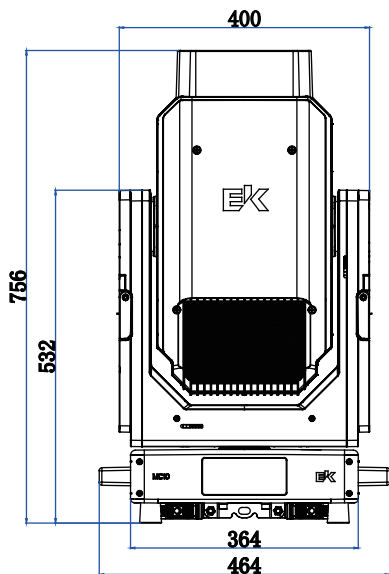

3. OVERVIEW

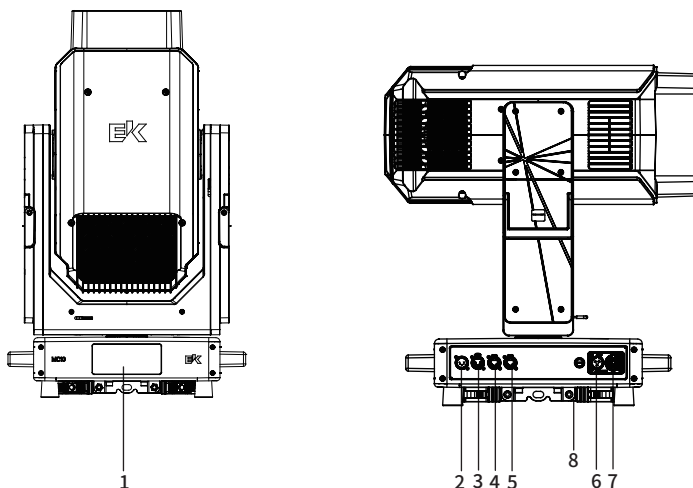

1.LCD Display

2.DMX In

3.DMX Out

4/5.Network port

6.Power In

7.Power Out

8.Integrated clamps

Display panel button function description

Control Panel	Illustration	Description	Function
Upper left button	Menu Option	Enter Menu	Menu Operation
Upper right button	Up	Scroll Up	Increase Numeric Value
Lower right button	Description	Scroll Down	Decrease Numeric Value
Lower left button	Confirm	Confirm	Save Setting

Initialization: MENU+ ✓

If you want to flip the display, hold UP + DOWN buttons for 3seconds to set display orientation.
 Without external power source, long press the right button for 3 seconds, enter the menu to set parameters

4 LITHING PARAMETERS

4.1 Technical parameters

MC10 technical parameters	
Optical parameters	
Light source	1000W 6-color LED light source module
Color temperature	1800K-10000K
Lumens	>21000LM
CCI	0
CRI	3200/5600K, Ra \geq 97, Other color temperature ranges \geq 95
R9	3200/5600K, R9 \geq 97, Other color temperature ranges \geq 95
DUV	0-0.003
Other color temperature ranges	None
Peak wavelength	None
TM-30-15rg/rf	3200K 95/103;5600K 96/102
TLCI	94@3200K; 97@5600K
Light source service life	20000H(Brightness is reduced to 70%, IF=3A)
Beam angle	5.2° -52°
Dynamic effects	
Pan	540°
Tilt	270°
Color mixing	R、G、B、C、A、M color mixing
Color disk	5+1
Gobo system 1	6 gobos+open
Gobo system 2	6 gobos+open
Animation wheel	Animation wheel with variable speed
Framing system	Single blade \pm 35°, rotatable \pm 60°
Zooming	Linear zooming 5.4-54°
Iris	15 elements, 15%-100% electronic linear iris
Frost	1° +5° linear, 0% - 100% frost
Strobe	1-30Hz
Dimming	0-100% linear dimming, 4 dimming curves, 22Bit
Prism	Bi-directional indexable 4-f round and 4-f linear prism
HUE	2.0M-2.0G adjustable
Electronic parameters	
Input voltage and frequency	100-240VAC 50/60Hz
Power	230V@1350W
Fuse	250V, T20A
Power connection	Seetronic TrueCon In/Out
Data connection	3pin XLR In/Out
Maximum number of power connections	2 units, 230V
Maximum number of data connections	32 units

Technical Parameters (continued)

Power factor	230V@0.95
Operating temperature	-10 ~ 45°C
Power Supply	Input voltage AC 100-240VAC 50/60Hz 1500W
Structural parameters	
Product size	464*308*746mm(omega brackets) 464*308*764mm(integrated clamps)
Product weight	Integrated clamps version: 34Kg/Omega brackets version: 33Kg
IP Grade	IP20
Cooling mode	Heat pipe cooling system and low-noise fan
Shell	Nylon, black fine sand texture
Installation	Floor-standing, side-mounted, hanging installation
Control	
Control method	DMX512/RDM/sACN/Artnet/bluetooth/APP/NFC
DMX Chart	51CH/43CH/45CH
Data connection	3pin XLR In/Out
Display	240RGB*320, 2.8 inches
Frequency	1.2KHz/25KHz
Built-in program	/
Pixel point control	/
Airtightness detection function	
Accessories	
Standard	Safety rope 1PCS, omega brackets (non-integrated clamps version), power cable

4.2 COLOR, GOBO, ANIMATION

Color

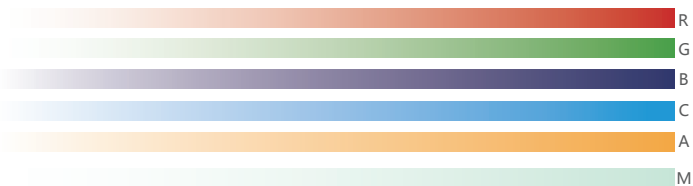

+Electronic Hue



+Electronic CTO

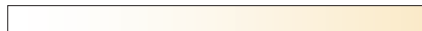

Rotating gobo



Rotating gobo2

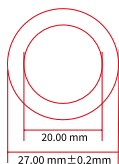

Animation Frame shutter

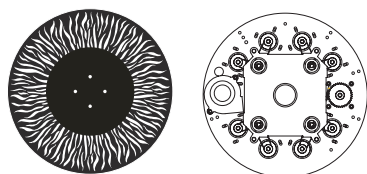

GOBO SYSTEM

Gobo outer diameter: 27mm \pm 0.2mm Gobo inner diameter: 20mm Thickness: 1.1mm

Gobo black side up
Gobo positioning point, gobo gear circular hole,
and rotating gobo plate substrate notch are
aligned in a straight line.

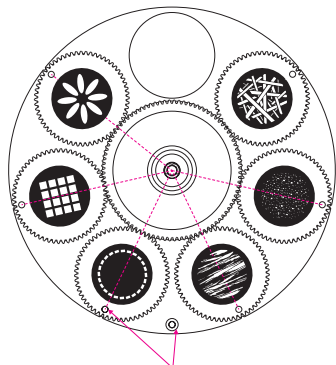

The magnetic steel sensing side faces upwards

Gobo black side up
Gobo positioning point, gobo gear circular hole,
and rotating gobo plate substrate notch are
aligned in a straight line.

Install the aperture first,
then the watermark
glass, and fix it with
glue, with the raised
side facing down.

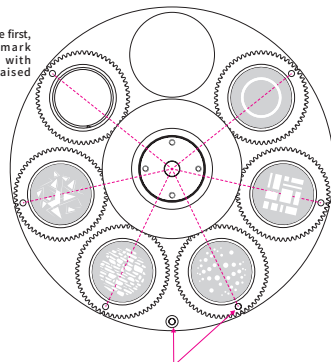

The magnetic steel sensing side faces upwards

Gobo change

When replacing the rotating gobo, please observe the following precautions:

1. Original gobos have a special coating designed to withstand high temperatures. Custom gobos must be made with high-Borofloat or higher glass. Custom gobos must match the original gobo in size, construction, material, and quality. Using gobos that do not meet these requirements will cause damage and void the product warranty.
2. Do not use gobos that have a black coating on both sides, as the black coating absorbs heat—both directly from the light source and reflected from other optics—and is not durable.
3. Wear clean nitrile gloves when replacing gobos.
4. Avoid scratching gobos.
5. Correct gobo orientation is crucial. Note the location of the registration points (indicated by the arrows) on the gobo wheel and gobo holder. Before removing the gobo holder from the gobo wheel, rotate the gobo wheel (twice if necessary) until the registration points are aligned perfectly. We recommend removing only one gobo holder at a time. After removing the gobo holder, do not rotate the gobo wheel to ensure that each gobo remains in the correct orientation and avoid the need for readjustment if the gobo orientation changes during operation.

Rotating gobo 1

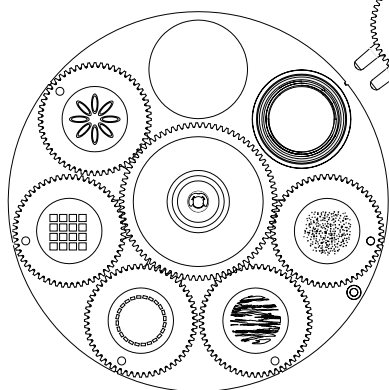

Water-rippled glass



Rotating gobo 2

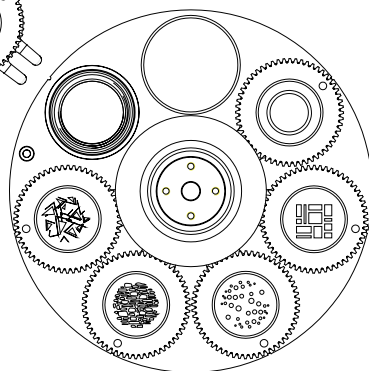

1. Gobo wheel

- a. Remove the two screws at A, unplug the power and signal adapter cables, and pull out the gobo assembly.

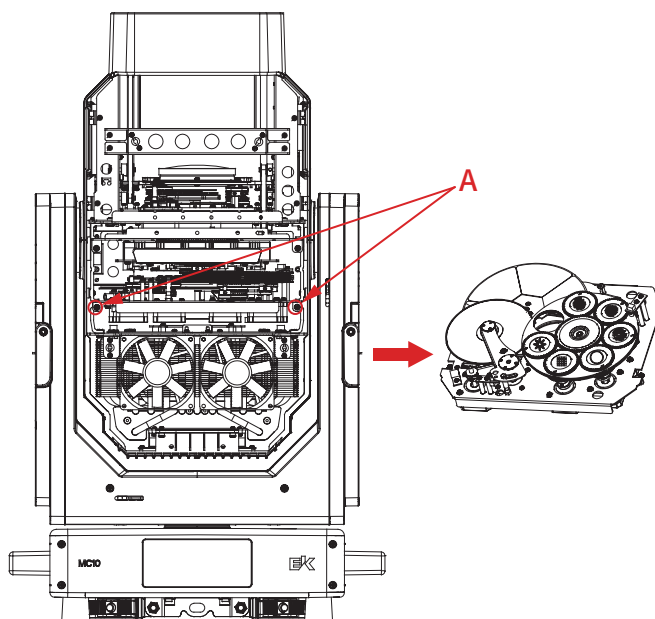

b. When removing the gobo holder from the gobo wheel, pay attention to how the gobo holder's tab engages the gobo wheel. When reinstalling the gobo holder, make sure to insert the tab back into the gobo wheel in the same position.

Rotating gobo 1

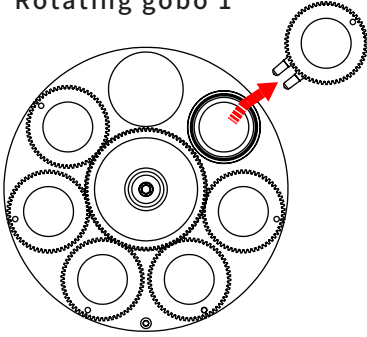

Rotating gobo 2

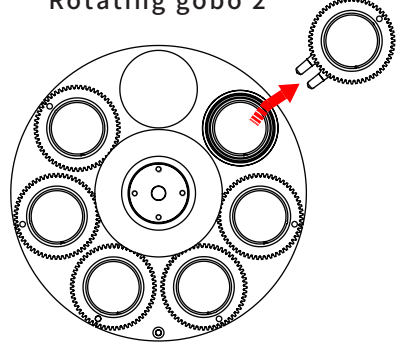

c. Use tweezers or other small objects to remove the retaining spring at C (if gobo is coated with glass glue for fixing, please use a professional cleaning agent to remove the glass glue before removing the retaining spring to avoid damaging gobo)

Rotating gobo 1
Gobo fixing seat



Rotating gobo 2
Gobo fixing seat

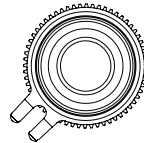

Rotating gobo wheel 1 with the toothed side of the gobo holder facing down (or rotate Gobo Wheel 2 with the toothed side of the gobo holder facing up), use an appropriate tool (such as a plastic crowbar) to carefully remove the gobo retaining clip, and then remove the original gobo.

Rotating gobo 1
Gobo fixing seat

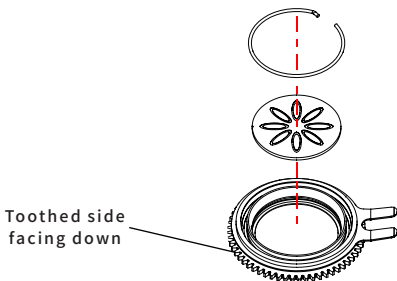

Rotating gobo 2
Gobo fixing seat

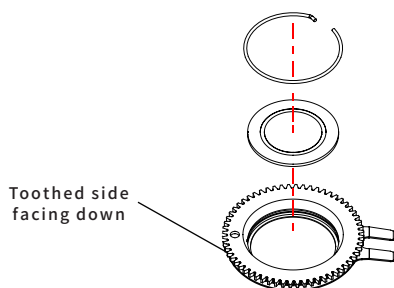

Hold the new gobo by its edges, being careful not to get fingerprints on it, and place it into the gobo holder, ensuring the locating points on the gobo and the gobo holder are aligned, with the black side (or flat side for water-patterned glass) facing down. Check that the gobo is fully seated in the gobo holder.

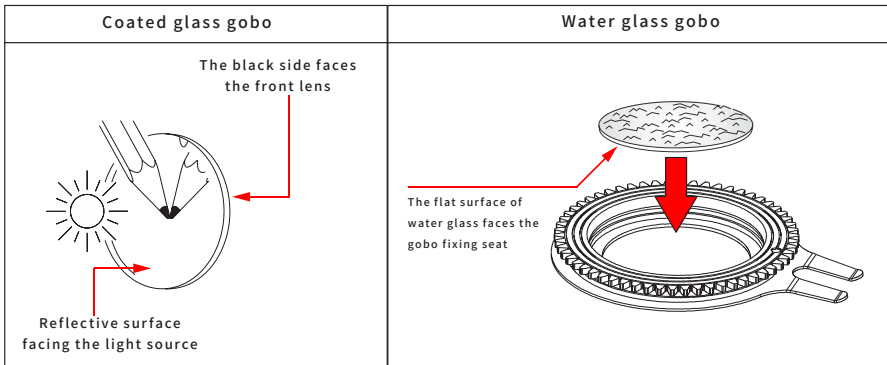
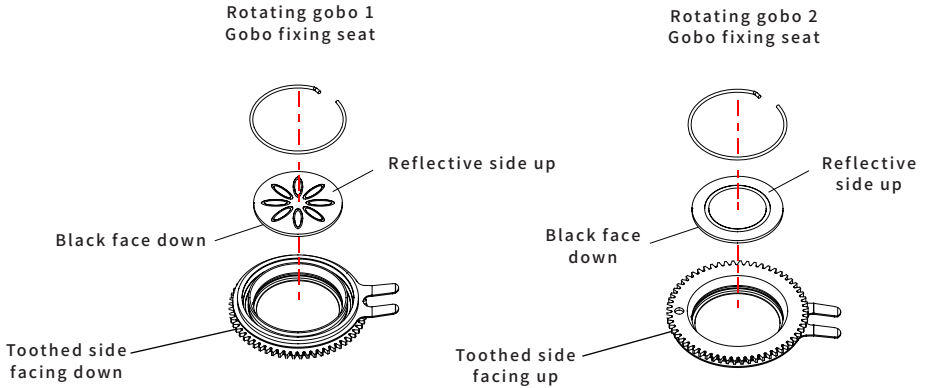

1. When reinstalling the gobo retaining clip, check that the clip is pressed as flatly as possible against the gobo and that the gobo is securely fastened in the gobo fixing seat.
2. Align the gobo holder with the positioning points on the gobo wheel and insert the tongue into the gobo wheel correctly when installing the gobo holder. After installation, check whether the gobo holder is firmly fixed to the gobo wheel.

4.3 PHOTOMETRICS

Beam Angle: 5.2°

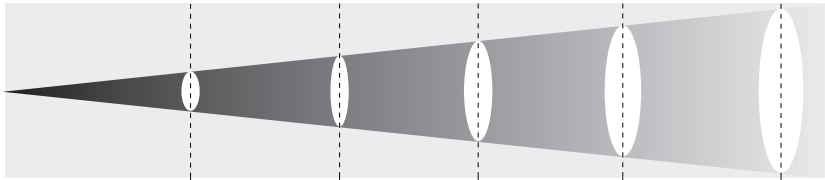

Distance(M)	5	10	15	20	25
3200K/CRI97 (Lux)	52000	13000	5778	3250	2080
5600K/CRI97 (Lux)	64300	16075	7144	4019	2572
All (Lux)	77700	19425	8633	4856	3108

Beam Angle: 52°

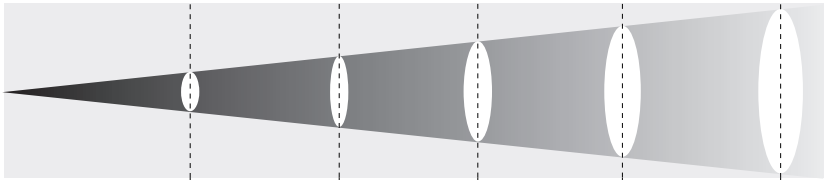

Distance (M)	5	10	15	20	25
3200K/CRI97 (Lux)	885	221	98	55	35
5600K/CRI97 (Lux)	1112	278	124	70	44
All (Lux)	1320	330	147	83	53

5 LIGHTING SETTINGS

5.1 Menu

Main Menu	Menu level 2	Menu level 3	Menu level 4	Menu level 5	Menu level 6	Default
1	DMX Setting	DMX Address	1-512			1
		DMX Channel	51CH-RGBCAM			51CH-RGBCAM
			45CH-CMY 43CH-XY			
2	Ethernet Setting	Protocol	Artnet			Artnet
			sACN			
		IP Address	xxx.xxx.xxx.xxx			/
		IP Mask	xxx.xxx.xxx.xxx			/
		Universe	0-65535 (Artnet)			0
			1-65535 (sACN)			
		Net To DMX	Off			Off
On						
Net To WDMX	Off			Off		
	On					
3	Movement Setting	Invert Pan	Off		Off	
			On			
		Invert Tilt	Off		Off	
			On			
		Swap Pan /Tilt	Off		Off	
			On			
		Encoder Pan/Tilt	Off		On	
			On			
		Absolute Encoder	Off		On	
			On			
		Framing Shutter Mode	Independent Mode			Mixed Mode
			Mixed Mode			
	Frost Mode	Independent Mode			Mixed Mode	
		Mixed Mode				
	Dimmer Setting	Dimmer Mode	Off		Off	
			Dimmer 1			
			Dimmer 2			
			Dimmer 3			
		Dimmer Curve	Linear		Square	
			Square Inverse Square S Curve			
	LED Frequency	1200 Hz	25KHz		1200 Hz	
			Off			
		Red Shift	On			
	Fan Mode	Auto		Auto		
On						
Off						
Silent						
Reset Setting	All		/			
	P/T		/			
	Head		/			
Display Setting	Back Light	Off		Off		
		On				
	Flip Display	No		No		
		Yes				
		Auto				
	Warn Cue	Off		On		
		On				
	Key Lock	No		Yes		
Yes						
Temperature Unit	°C		°C			
	°F					
SunSafe	Yes		Yes			
	No					

5.2 Menu

4	TEST	Channel	Arrange according to the current channel mode				/	
							/	
		AUTO	Pan/Tilt					/
			Head					/
		All						
5	ADVANCED	Code:xxx	Color Calibration	Off				
				User Calibration	Red	125~255		Off
					Green	125~255		
					Blue	125~255		
					Cyan	125~255		
					Amber	125~255		
				Mint	125~255			
			Factory Calibration					
			Calibration	Pan Offset			128	
				Tilt Offset			128	
				Color Offset			128	
				Gobo1 Offset			128	
				RGobo1 Offset			128	
				Gobo2 Offset			128	
				RGobo2 Offset			128	
				Effect Offset			128	
				Iris Offset			128	
				Prism1 Offset			128	
				RPrism1 Offset			128	
				Prism2 Offset			128	
				RPrism2 Offset			128	
				Focus Offset			128	
				Zoom Offset			128	
				Frost Offset			0	
				Frost1 Offset			0	
				Shutters Rot. Offset			128	
				Fr.shutter 1 M1 Offset			0	
				Fr.shutter 1 M2 Offset			0	
				Fr.shutter 2 M1 Offset			0	
				Fr.shutter 2 M2 Offset			0	
				Fr.shutter 3 M1 Offset			0	
			Fr.shutter 3 M2 Offset			0		
			Fr.shutter 4 M1 Offset			0		
Fr.shutter 4 M2 Offset			0					
Factory Reset	No			/				
	Yes			/				
6	Information	System Errors				/		
		Time	Fixture Hours	65535H		0		
			Led Hours	65535H		0		
		Version	DISP	V1.0		/		
			CTR1-XY	V1.0		/		
			CTR2-MOTOR	V1.0				
			CTR3-MOTOR	V1.0				
			CTR4-MOTOR	V1.0				
			CTR5-LED	V1.0				
			Bluetooth	V1.0		/		
		DMX Monitor						
		Temperature	LED1: 40°C			/		
UID:	*****			/				

6. INSTALLATION

6.1 Installation instructions and precautions

6.1.1 Installation instruction

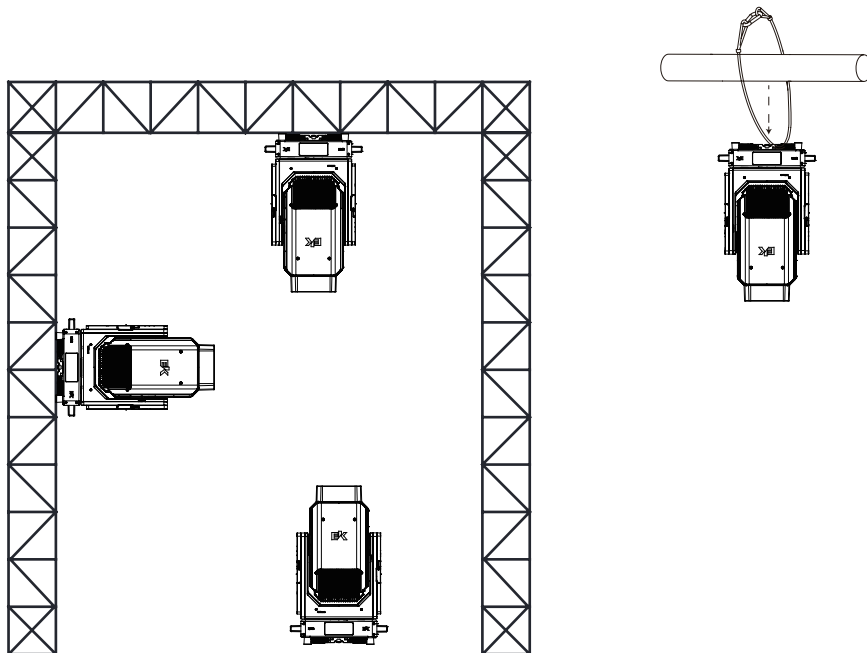

Installation should be performed by qualified personnel and should be done away from pedestrian paths, seating areas, or areas where unauthorized personnel might reach the luminaire. Never stand directly under the luminaire during assembly, disassembly, or maintenance. When installing the luminaire, ensure it is securely fastened to prevent it from vibrating and falling during operation. Ensure that the structure holding the luminaire can support ten times its weight without deformation. When installing the luminaire, use a safety cable capable of supporting twelve times its weight to prevent it from falling if the fixture fails.

This fixture is fully operational in 2 different mounting positions: hanging upside down, or placed on a flat, horizontal surface. Always use and install a safety cable as a safety measure to prevent accidental damage to the fixture or personal injury in the event of fixture failure.

6.1.2 Hanging installation

1. When installing the device, be sure to keep it away from flammable items (decorative materials, etc.), keeping a distance of at least 0.5 meters.
2. When hanging, be sure to install a safety rope with a load-bearing capacity of at least 10 times the weight of the lamp.
3. When hanging, the device for fixing the lamp must use a mounting bracket that can bear at least 10 times the weight of the lamp.
4. As shown in the figure, the safety rope needs to pass through the safety rope hole of the lamp and the mounting bracket to ensure that the structure connected to the lamp is firm.

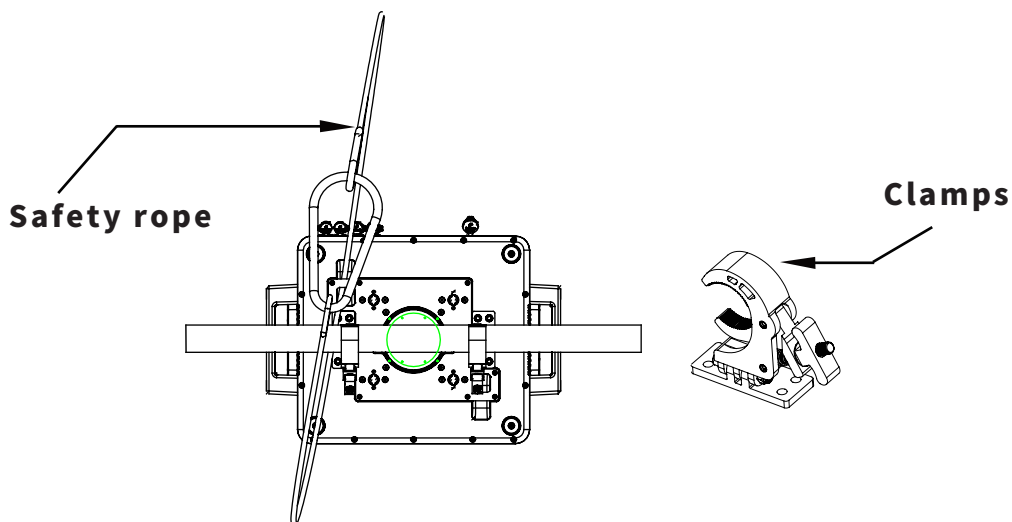

6.2 POWER CONNECTION

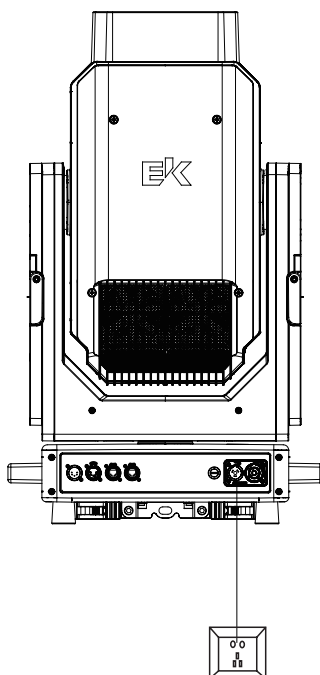

Power connection instructions



Power In

This product uses a Powercon in single connection power cord

Note: Due to power reasons, a 2.5mm² power cord can only support up to 2 units (230V)



Warning

Do not connect too many lamps to a single power cord or overload it. Do not use a power cord with damaged insulation, and do not place the power cord over other wires.

When the lamp is not in use or is being cleaned, please unplug the power cord.

Do not pull the power cord with force or pull it directly.

6.3 SIGNAL CONNECTION

Network connection

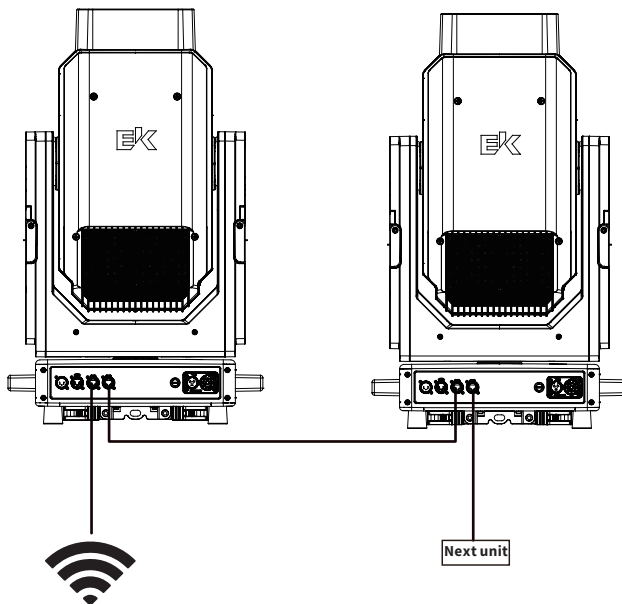

DMX Connection

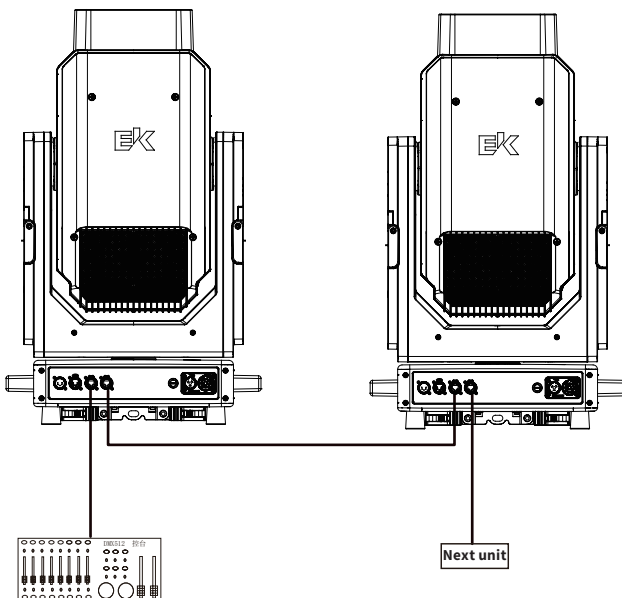

DMX CONNECTION INSTRUCTIONS

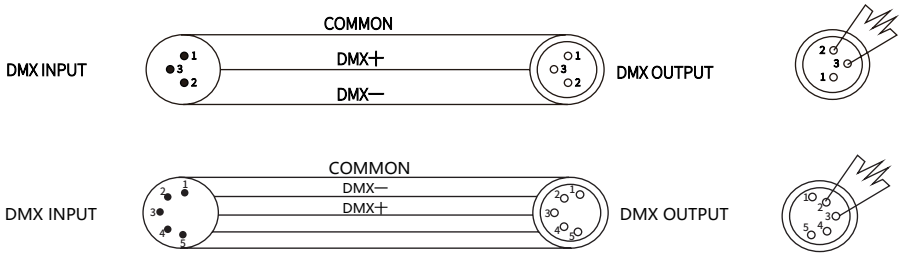

- In order to reduce signal errors and avoid signal attenuation and interference during transmission, you can add a 120 ohm 1/4W resistor between the 2nd and 3rd pins of the DMX output terminal of the last machine.
- Connect the fixtures with XLR cables, connecting one end to the output port of one fixture and the other end to the input port of the next fixture. Cables should only be used in series, not in parallel. Because DMX512 signals transmit very quickly, damage to the cable, loose solder joints, or poor contact can affect signal transmission and cause the system to shut down.
- When the power supply of a unit is cut off, the DMX output and input connections are bypassed to maintain the connectivity of the DMX line.
- Each lamp must have an address code to receive information from the console.
- The terminal of the DMX512 system needs to be equipped with a terminator to reduce errors in signal transmission.

DMX Address code setting

MODE	Allocation	Address of 1st fixture	Address of 2st fixture	Address of 3st fixture	Address of 4st fixture
51CH	001-051	001	052	102	152

(Refer to the figure above) The number of lamps added after the 4th one; the address code is based on the channel, and so on.

6.4 DMX Chart

51CH RGBCAM	45CH CMY	43CH XY	Function	Value	Description	Remark
1	1	1	Pan	000-255		
2	2	2	Pan Fine	000-255		
3	3	3	Tilt	000-255		
4	4	4	Tilt Fine	000-255		
5	5	5	Shutter	000-010	Close	
				011-082	Shutter effect slow to fast	
				083-093	Open	
				094-163	Pulse-effect in sequences	
				164-174	Open	
				175-244	Random Shutter effect slow to fast	
				245-255	Open	
6	6	6	Dimmer	000-255	Dimmer 0%-100%	
7	7	7	Dimmer Fine	000-255	Dimmer Fine	
8	8	8	CTO	000-000	No Effect	
				001-027	1800K - 2200K	
				028-052	2200K - 2600K	
				053-078	2600K - 2800K	
				079-103	2800K - 3200K	
				104-129	3200K - 4000K	
				130-154	4000K - 5600K	
				155-180	5600K - 6500K	
				181-205	6500K - 7500K	
				206-231	7500K - 8500K	
				232-255	8500K - 10000K	
9	9	9	HUE	000-001	No Effect	
				002-003	Full Minus Green	
				004-126	-99% to 1%	
				127-128	No Effect	
				129-253	1% to 99%	
				254-255	Full Plus Green	
10	10	10	CCT CrossFade to Color	000-255		
11	/	/	Red	000-255		
12	/	/	Red Fine	000-255		
13	/	/	Green	000-255		
14	/	/	Green Fine	000-255		
15	/	/	Blue	000-255		
16	/	/	Blue Fine	000-255		
17	/	/	Cyan	000-255		
18	/	/	Cyan Fine	000-255		
19	/	/	Amber	000-255		
20	/	/	Amber Fine	000-255		
21	/	/	Mint	000-255		
22	/	/	Mint Fine	000-255		
/	/	11	/	Cyan		
/	/	12	/	Cyan Fine		
/	/	13	/	Magenta		
/	/	14	/	Magenta Fine		
/	/	15	/	Yellow		
/	/	16	/	Yellow Fine		
/	/	11	X			
/	/	12	X Fine			
/	/	13	Y			
/	/	14	Y Fine			
23	17	15	Color Wheel	000-010	Open	
				011-021	Open + Color1	
				022-031	Color 1	
				032-042	Color 1 + Color 2	
				043-053	Color 2	
				054-063	Color 2 + Color 3	
				064-074	Color 3	
				075-085	Color 3 + Color 4	
				086-095	Color 4	
				096-106	Color 4 + Color 5	
				107-117	Color 5	
				118-127	Color 5 + Open	
				128-190	Fast to Slow(Forward Spin)	
				191-192	Stop (Stop Rotation)	
				193-255	Slow to Fast(Revers Spin)	

6.4.2 DMX Chart

24	18	16	Gobo1	000-010	Open	
				011-020	Gobo1	
				021-030	Gobo2	
				031-040	Gobo3	
				041-050	Gobo4	
				051-060	Gobo5	
				061-071	Gobo6	
				072-113	Fast to Slow(Revers Spin)	
				114-117	Stop (Stop Rotation)	
				118-159	Slow to Fast(Forward Spin)	
				160-175	Gobo1 Shaking Slow to Fast	
				176-191	Gobo2 Shaking Slow to Fast	
				192-207	Gobo3 Shaking Slow to Fast	
				208-223	Gobo4 Shaking Slow to Fast	
				224-239	Gobo5 Shaking Slow to Fast	
				240-255	Gobo6 Shaking Slow to Fast	
				25	19	17
128-190	Fast to Slow(Forward Spin)					
191-192	Stop (Stop Rotation)					
193-255	Slow to Fast(Revers Spin)					
26	20	18	Gobo2	000-010	Open	
				011-020	Gobo1	
				021-030	Gobo2	
				031-040	Gobo3	
				041-050	Gobo4	
				051-060	Gobo5	
				061-071	Gobo6	
				072-113	Fast to Slow(Revers Spin)	
				114-117	Stop (Stop Rotation)	
				118-159	Slow to Fast(Forward Spin)	
				160-175	Gobo1 Shaking Slow to Fast	
				176-191	Gobo2 Shaking Slow to Fast	
				192-207	Gobo3 Shaking Slow to Fast	
				208-223	Gobo4 Shaking Slow to Fast	
				224-239	Gobo5 Shaking Slow to Fast	
				240-255	Gobo6 Shaking Slow to Fast	
				27	21	19
128-190	Fast to Slow(Forward Spin)					
191-192	Stop (Stop Rotation)					
193-255	Slow to Fast(Revers Spin)					
28	22	20	Prism1	000-127	Prism Excluded	
				128-255	Prism Inserted	
29	23	21	RPrism1	000-127	0 - 540 Position	
				128-190	Fast to Slow(Forward Spin)	
				191-192	Stop (Stop Rotation)	
				193-255	Slow to Fast(Revers Spin)	
30	24	22	Prism2	000-127	Prism Excluded	
				128-255	Prism Inserted	
31	25	23	RPrism2	000-127	0 - 540 Position	
				128-190	Fast to Slow(Forward Spin)	
				191-192	Stop (Stop Rotation)	
				193-255	Slow to Fast(Revers Spin)	
32	26	24	Frost 1/2	000-255	Frost 0->100%	Mixed Mode
			Frost 1	000-255	Frost 0->100%	
			Frost 2	000-255	Frost 0->100%	Independent Mode
34	28	26	Effect	000-127	Effect Excluded	
				128-255	Effect Inserted	
35	29	27	REffect	000-003	Effect Inserted	
				004-127	Fast to Slow(Forward Spin)	
				128-132	Stop (Stop Rotation)	
				133-255	Slow to Fast(Revers Spin)	
36	30	28	Iris	000-127	Maximum to Minimum Aperture	
				128-131	Maximum Aperture	
				132-171	Slow to Fast Pulsation	
				172-211	Slow to Fast Pulsation,Fast Opening	
				212-251	Slow to Fast Pulsation,Fast Closing	
				252-255	Maximum Aperture	

6.4.3 DMX Chart

37	37	29	Focus	000-255		
38	32	30	Focus Fine	000-255		
39	33	31	Zoom	000-255		
40	34	32	Zoom Fine	000-255		
41	35	33	Auto Focus	000-010	Auto Focus OFF	Hole
				011-020	4 - 6 metres	
				021-030	6 - 8 metres	
				031-040	8 - 10 metres	
				041-050	10 - 12 metres	
				051-060	12 - 14 metres	
				061-070	14 - 16 metres	
				071-080	16 - 18 metres	
				081-090	18 - 20 metres	
				091-100	4 - 6 metres	
				101-110	6 - 8 metres	
				111-120	8 - 10 metres	
				121-130	10 - 12 metres	
				131-140	12 - 14 metres	
				141-150	14 - 16 metres	RGobo2
				151-160	16 - 18 metres	
				161-170	18 - 20 metres	
				171-180	4 - 6 metres	
				181-190	6 - 8 metres	
				191-200	8 - 10 metres	
				201-210	10 - 12 metres	
				211-220	12 - 14 metres	
				221-230	14 - 16 metres	
				231-240	16 - 18 metres	
				241-250	18 - 20 metres	
251-255	Auto Focus OFF					
42	36	34	Framing Shutter 1 movent	000-255	Movement from outward to inward	Framing Shutter Mixed Mode
			Framing Shutter 1_1 movent	000-255	Movement from outward to inward	Framing Shutter Independent Mode
43	37	35	Framing Shutter 1 swivelling	000-127	Swivelling from -25 degrees towards 0 degrees	Framing Shutter Mixed Mode
				128	0 degrees	
				129-255	Swivelling from 0 degrees to +25 degrees	
			Framing Shutter 1_2 movent	000-255	Movement from outward to inward	Framing Shutter Independent Mode
44	38	36	Framing Shutter 2 movent	000-255	Movement from outward to inward	Framing Shutter Mixed Mode
			Framing Shutter 2_1 movent	000-255	Movement from outward to inward	Framing Shutter Independent Mode
45	39	37	Framing Shutter 2 swivelling	000-127	Swivelling from -25 degrees towards 0 degrees	Framing Shutter Mixed Mode
				128	0 degrees	
				129-255	Swivelling from 0 degrees to +25 degrees	
			Framing Shutter 2_2 movent	000-255	Movement from outward to inward	Framing Shutter Independent Mode
46	40	38	Framing Shutter 3 movent	000-255	Movement from outward to inward	Framing Shutter Mixed Mode
			Framing Shutter 3_1 movent	000-255	Movement from outward to inward	Framing Shutter Independent Mode
47	41	39	Framing Shutter 3 swivelling	000-127	Swivelling from -25 degrees towards 0 degrees	Framing Shutter Mixed Mode
				128	0 degrees	
				129-255	Swivelling from 0 degrees to +25 degrees	
			Framing Shutter 3_2 movent	000-255	Movement from outward to inward	Framing Shutter Independent Mode

6.4.4 DMX Chart

48	42	40	Framing Shutter 4 movent	000-255	Movement from outward to inward	Framing Shutter Mixed Mode
			Framing Shutter 4_1 movent	000-255	Movement from outward to inward	Framing Shutter Independent Mode
49	43	41	Framing Shutter 4 swivelling	000-127	Swivelling from -25 degrees towards 0 degrees	Framing Shutter Mixed Mode
				128	0 degrees	
			Framing Shutter 4_2 movent	129-255	Swivelling from 0 degrees to +25 degrees	Framing Shutter Independent Mode
50	44	42	Framing Shutter Rotation	000-127	Rotation from left to center	
				128	Center	
				129-255	Rotation from center to right	
51	45	43	Control(Hold 3 Second)	000-005	None	
				006-010	Dimmer Mode Off	
				011-015	Dimmer Mode 1	
				016-020	Dimmer Mode 2	
				021-025	Dimmer Mode 3	
				026-030	Dimmer curve Linear	
				031-035	Dimmer curve Exponential	
				036-040	Dimmer curve Logarithmic	
				041-045	Dimmer curve S	
				046-050	Reserve	
				051-055	Led Frequency=1200Hz	
				056-060	Reserve	
				061-065	Reserve	
				066-070	Reserve	
				071-075	Led Frequency=25000Hz	
				076-080	Pan Inverse Off	
				081-085	Pan Inverse On	
				086-090	Tilt Inverse Off	
				091-095	Tilt Inverse On	
				096-100	Swap Pan Tilt Off	
				101-105	Swap Pan Tilt On	
				106-110	Auto	
				111-115	On	
				116-120	Off	
				121-125	Silent	
				126-130	Color Calibration Off	
				131-135	Reserve	
				136-140	Factory Calibration	
				141-150	Reserve	
				151-155	Red Shift Off	
				156-160	Red Shift On	
				161-165	Framing Shutter Independent Mode	
				166-170	Framing Shutter Mixed Mode	
				171-175	FrostIndependent Mode	
				176-180	Frost Mixed Mode	
				181-240	Reserve	
241-245	Head Reset					
246-250	Pan/Tilt Reset					
251-255	Complete Reset					

7 Errors

1	CTR1-X Error
2	CTR2-Y Error
3	CTR3-MOTOR Error
4	CTR4-MOTOR Error
5	CTR5-MOTOR Error
6	CTR6-LED Error
7	Pan Sensor Error
8	Pan Encode Error
9	Tilt Sensor Error
10	Tilt Encode Error
11	Gobo1 Reset Fail
12	RGobo1 Reset Fail
13	Gobo2 Reset Fail
14	RGobo2 Reset Fail
15	4Prism Reset Fail
16	4RPrism Reset Fail
17	8Prism Reset Fail
18	8RPrism Reset Fail
19	Focus Reset Fail
20	Zoom Reset Fail
21	Frost Reset Fail
22	Temperature Error
23	Fan Error
24	Gravity Error
25	Humidity Error
26	All TimeOut

8 TROUBLESHOOTING

Fault phenomenon	Fault cause	Handling method
No menu displayed	<ol style="list-style-type: none"> 1.No AC input 2.Power supply failure 3.Display panel failure 	<ol style="list-style-type: none"> 1.Check the power supply circuit 2.Check the switching power supply for voltage output 3.Replace the display panel
Unable to receive DMX signal	<ol style="list-style-type: none"> 1.DMX signal line failure 2.The signal line wiring sequence is wrong 3.The signal input receiving signal IC is damaged 4.The DMX address code setting does not match the control corresponding to the console 5.Other parameter settings are incorrect 6.After entering the menu, exit to the main menu without pressing the confirm button or MENU button 	<ol style="list-style-type: none"> 1.Check or replace the signal cable 2.Check wiring sequence of signal lines 3.Check if display panel signal receiving IC and two resistors in series on signal line are open. 4.Check or reset address code or restore to factory settings and try again 5.Press MENU to exit to main menu
The surface temperature of lamp body exceeds 75°, temperature control protection cannot be performed	<ol style="list-style-type: none"> 1. Thermistor on LED bead board is faulty 2. Faulty temperature control circuit on display panel 	<ol style="list-style-type: none"> 1. Replace the thermistor 2. Check temperature control circuit on mainboard
Uneven light color mixing	<ol style="list-style-type: none"> 1.Improper LED soldering 2.The lens or bracket is not installed properly 	<ol style="list-style-type: none"> 1.Check welding condition of LED beads 2.Check lens assembly process and adjust bracket assembly direction
The light has a color cast (reddish, greenish or bluish)	<ol style="list-style-type: none"> 1.The current of one set of LED colors is too large or too small 2.Improper RGBW color mixing white balance setting 	<ol style="list-style-type: none"> 1.Check driving current of the corresponding color group of the driver board 2.Reset or restore factory settings 3.Replace the corresponding IC
The lamp is not lit or flickers slightly	<ol style="list-style-type: none"> 1.LED is damaged or driver board has no current output 	<ol style="list-style-type: none"> 1.Replace LED lamp beads 2.Replace damaged LED or check driver board circuit 3.Replace the corresponding driver IC
Parameters are not saved	The IC used to store parameters is damaged	Replace the memory IC
The whole lamp does not work when powered on	When temperature is too high, temperature control protection causes the switching power supply over-temperature protection to not work	Wait until the lamp cools down before turning it on again

9 MAINTENANCE AND CARE

- 1.Regular cleaning is very important to life and performance of lamp. The accumulation of dust, dirt, smoke particles, atomized liquid residue, etc. will reduce the light output and heat dissipation ability of lamp.
- 2.The cleaning time of lamps varies greatly depending on the operating environment, so it is impossible to specify a precise cleaning interval for lamps.

Environmental factors that may require more frequent cleaning include:

Use a fogger or mist machine.

High air flow rates (for example, near air conditioning vents).

Airborne dust (e.g. from stage effects, building structures and decorations, or the natural environment at outdoor events).

If one or more of these factors are present, check the fixture for cleaning needs within the first few hours of operation. Continue checking the fixture frequently thereafter. This process will enable you to assess the need for cleaning in your specific situation.

When cleaning lamps, pay attention to the following points:

Do this in a clean, dry, well-lit area.

Only wipe gently. We recommend using a soft, lint-free cloth with water or a mild detergent solution. Do not use alcohol, solvents, or abrasives under any circumstances! Be extremely careful when cleaning optical components: their surfaces are fragile and easily scratched.

CLEANING PROCESS



Warning

Disconnect the power supply before opening any covers

Wipe optical components gently; the coating surface is very brittle and easily scratched. Do not use aggressive solvents that may damage the plastic or coating surface.

Cleaning optics:

- 1.After power off, cool thoroughly and open the lid.
- 2.Use a vacuum cleaner or pressure blower to gently blow away dust and floating objects
- 3.Use unscented tissue paper or cotton cloth soaked in clean or distilled water to wipe off the particles. Do not wipe the surface. Use pressurized air to blow away floating objects.
- 4.Use cotton cloth soaked in ethyl propylene glycol or unscented tissue paper to remove smoke and residue. You can also use glass cleaner, but the residue must be removed with distilled water. Wipe in circles from the center to the sides, then wipe dry with a soft cotton cloth.
- 5.Clean the fan and air vents. Use a soft brush, tissue paper, air vacuum cleaner or pressure blower to remove dust from the fan and air vents.

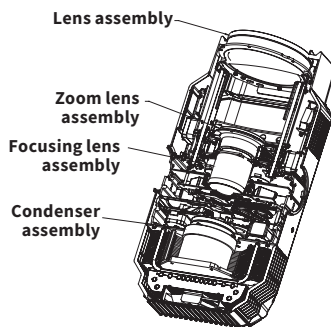

Schematic diagram of each lens group of the whole lamp

(The light-emitting lens, focus lens, zoom lens, and condenser lens markings need to be wiped)

10 EXPLODED VIEW OF THE LAMP STRUCTURE

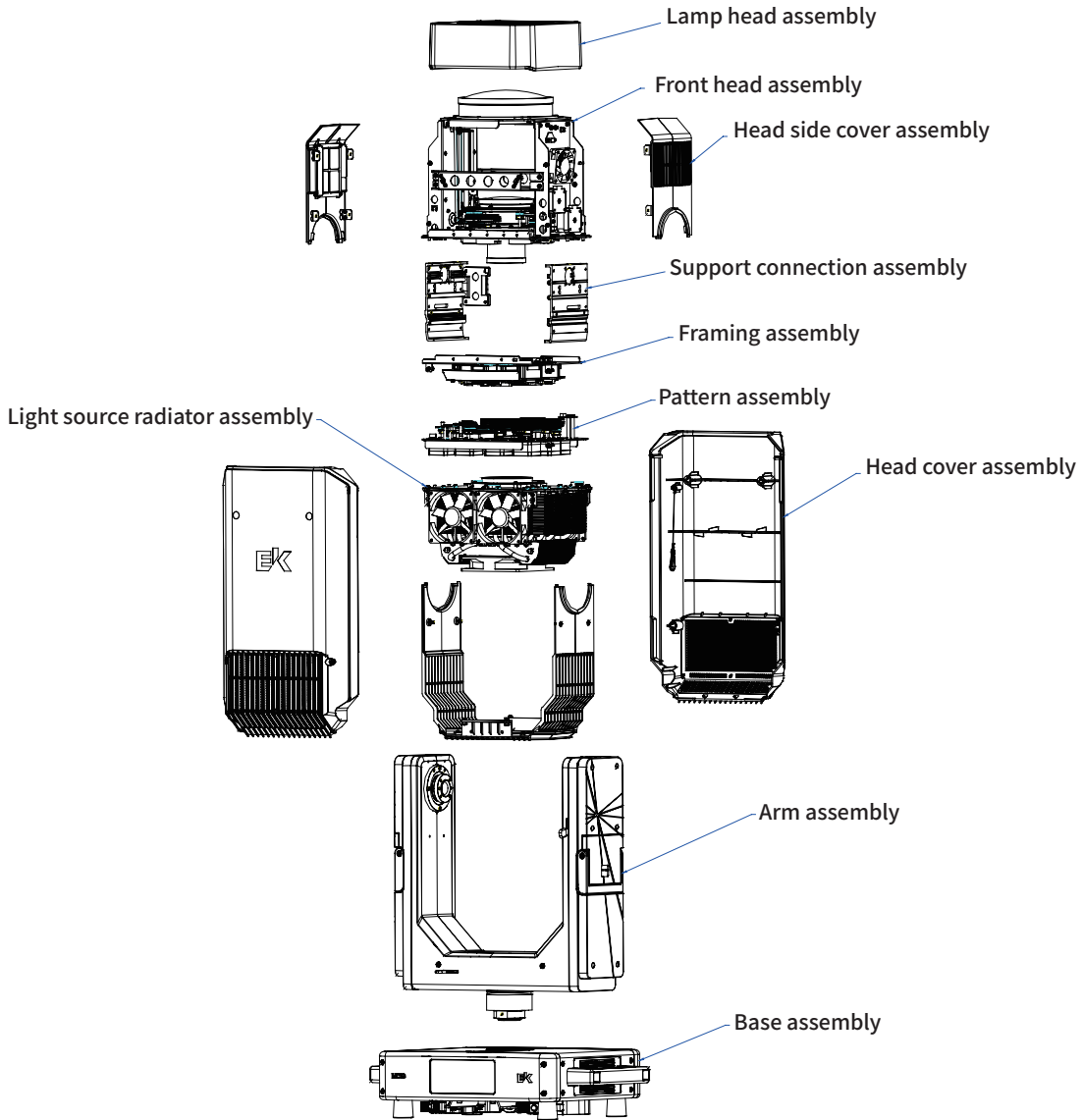



EKINC.

Address: NO.55 Zhongzhun Road, Cuiheng New District, Zhongshan City, Guangdong Province

Phone: 0086 (0760) 88280099

www.eklights.com