

Radiant 3000+

USER MANUAL

CONTENTS

1. SAFETY GUIDE	01
3. DIMENSION.....	02
4. OVERVIEW	03
4. SPECIFICATION	04
5. PHOTOMETRICS	05
5. LIGHTING SETTINGS	06
5.1 Menu.....	06
6. INSTALLATION	09
6.1 Installation instructions and precautions	09
6.2 Power Connection	11
6.3 SIGNAL CONNECTION	12
6.4 DMX Chart	14
7. TROUBLESHOOTING	28
8. MAINTENANCE AND CARE.....	29
9. PIXEL MAPPING.....	30
10. EXPLODED VIEW	31

1. SAFETY GUIDE



The products are packed in good condition when leaving factory. Please operate according to the user manual. Machine failure caused by human factors is not covered by the warranty.



When electrical equipment is in operation, be careful of electric shock and do not touch it!



Do not look directly at the light source to avoid damage to your eyes.



To protect environment, please dispose of/recycle the product according to local regulations at the end of its life.

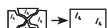

NOTE: Replace any screen that is cracked.

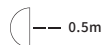

The shortest distance from the object to be illuminated is 0.5meters.

- The light source in this luminaire shall be replaced by the manufacturer, its service agent or a similarly qualified person. If the external flexible cable or cord of this luminaire is damaged, the cord shall be replaced by a qualified person of the manufacturer or its service agent to avoid a hazard.
- After receiving the lamp, please check whether there is any damage caused by transportation. If there is any damage, do not use the lamp and contact the supplier or manufacturer immediately.
- The lamp should be installed in a well-ventilated place, at least 50cm away from the wall, and check whether the ventilation holes are unobstructed.
- Please do not open the lamp to repair it yourself.
- Electrical connections must be made by qualified installers.
- Each lamp should be safely grounded and the electrical installation should be carried out in accordance with relevant standards.
- Do not use a power cord with damaged insulation, and do not place the power cord on other wires. When the lamp is not in use or is being cleaned, unplug the power cord. Do not unplug or pull the power cord forcefully or directly.
- After working at full power for 10 minutes, the surface temperature of the lamp is about 40 degrees. After stable operation, the surface temperature of the lamp should be around 70 degrees.
- There are no user-serviceable parts inside this lamp. Before operating the lamp, please check that all parts are well connected and the screws are secure.
- If you have any questions, please contact the supplier or manufacturer in time.

3.DIMENSION

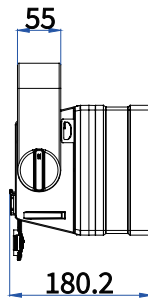
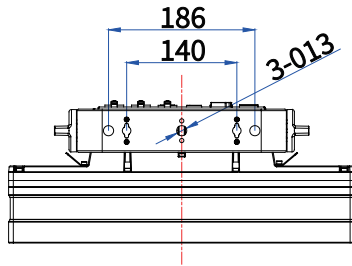
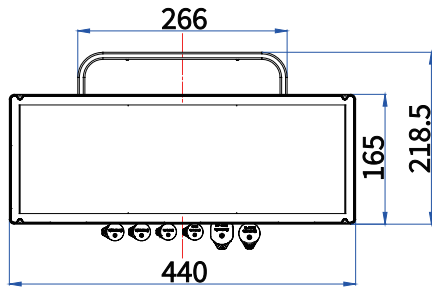

4. OVERVIEW

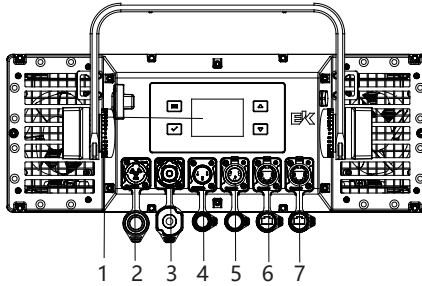

1.Display

2. Power In

3.Power Out

4.DMX In

5.DMX Out

6/7. Ethernet port

Display panel button function description

Control Panel	Illustration	Description	Function
	Menu Option	EnterMenu	Menu Operation
	Up	Confirm	Increase Numeric Value
	Description	Scroll Down	Decrease Numeric Value
	Confirm	Confirm	Save Setting

Initialization: +

If you want to flip the display, hold UP + DOWN buttons for 3seconds to set display orientation.

Without external power source, long press the right button for 3 seconds, enter the menu to set parameters

4. SPECIFICATION

Specification of Radiant 3000+	
PHOTOMETRICS	
Light Source	RGBW 4-in-1 LED: 4W*720
Color Temperature	2800-10000K
Output	Cold engine: ALL:44016Lm Heat engine: ALL:26983Lm Instant peak value of strobing: 150,000 Lm
Illuminance	Cold engine: ALL:2001Lux @3m Heat engine: ALL:1182Lux @3m
CRI	> 90
R9	> 90
DUV	± 0.002
Main wavelength	R:622nm G:527nm B:455nm W:583nm
Peak wavelength	R:630nm G:519nm B:449nm W:605nm
TM-30-15rg/rf	3200K:104/93, 5600K:105/91
TLCI	> 80
Lifespan	30000h
Beam Angle	118.4°
Field Angle	158.7°
Safety Distance	0.5m
KEY FEATURE	
Tilt Movement	180° (Manual)
Color System	RGBW
	2800K ~ 10000K
Strobe	1 ~ 30Hz
Dimming	4 dimming curves, 0 ~ 100% linear dimming
POWER	
Mains	100 ~ 240VAC, 50 ~ 60Hz-37.3V*25.5A=951
Consumption	Static: 1007W@230V ; 1038W@120V
Power Connection	2PCS@230V, 1PC@120V
Data Connection	DMX In/Out, linking up to 32pcs
Power Factor	0.99@120V 0.98@230V
Ambient	-20° ~ 45°;
PSU	100-240VAC 50/60Hz/37V*32.4A=1200W(rated power)
CONTROL	
Protocol	DMX512/Art-Net/sACN/RDM
DMX Channels	Basic Static-5CH/Basic Strobe-6CH/Basic Pixels-241CH/Basic RGBW STROBE-13CH/ PIXELS 60PX-249CH/PIXELS 36PX-153CH/PIXELS 30PX-129CH/PIXELS 18PX-81CH/ PIXELS 12PX-57CH/PIXELS 3PX-21CH/PIXELS 12PX-2-57CH/ PIXELS 6PX-33CH/PIXELS 5PX-29CH/PIXELS 4PX-25CH/PIXELS 3PX-2-21CH/PIXELS 1PX-13CH/ ADVANCED 1-21CH/ADVANCED 2-257CH/ADVANCED 3-33CH/ADVANCED 4-269CH
Display	240RGB*320 2.8-inch TFT display
Refresh Frequency	1KHz/2KHz/4KHz/6KHz/25KHz
Pixel Matrix	12*5
PHYSICAL	
Dimension	440mm*218.5mm*180.2mm
Weight	9.5KG
IP rating	IP66
Cooling System	IP noiseless fan
Housing	Die-cast magnesium Alloy
Installation	Sit-flat floor mounting, side hanging and flown mounting

5. PHOTOMETRICS

Beam Angle 118° (Cold Engine)

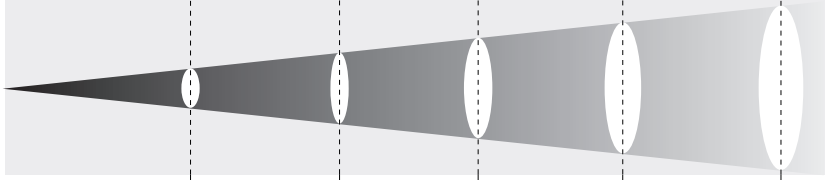

Distance(m)	3m	5m	7m	10m	20m
R(Lux)	604	217	111	54	14
G(Lux)	1717	618	315	155	39
B(Lux)	285	103	52	26	6
W(Lux)	2082	750	382	187	47
ALL(Lux)	2001	720	368	180	45

Beam Angle 118° (Heat Engine)

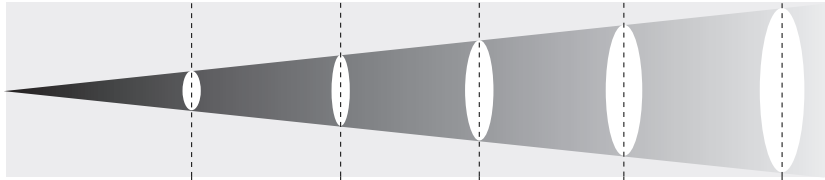

Distance(3m)	3m	5m	7m	10m	20m
R(Lux)	253	91	46	23	6
G(Lux)	976	351	179	88	22
B(Lux)	170	61	31	15	4
W(Lux)	1188	428	218	107	27
ALL(Lux)	1182	426	217	106	27
2800K(Lux)	918	330	169	83	21
3200K(Lux)	1190	428	219	107	27
4000K(Lux)	1210	436	222	109	27
5600K(Lux)	1150	414	211	104	26
6500K(Lux)	1140	410	209	103	26
8000K(Lux)	1193	429	219	107	27
10000K(Lux)	1071	386	197	96	24

5.LIGHTING SETTINGS

5.1 MENU

\	Main Menu	Menu level 2	Menu level 3	Menu level 4	Menu level 5	Remark		
1	DMX Setting	DMX Address	1-512					
		DMX Channel	Basic		STATIC			
				STROBE		R=0~255		
						G=0~255		
						B=0~255		
						W=0~255		
				PIXEL				
				RGBW STROBE				
			Pixels		PIXELS60	Pixel Mapping		
					PIXELS30			
					PIXELS36			
					PIXELS18			
					PIXELS12			
					PIXELS3			
				PIXELS12 2				
				PIXELS5				
				PIXELS6				
				PIXELS4				
			PIXELS3 2					
			PIXELS 1					
Advanced		ADVANCED 1						
		ADVANCED 2						
		ADVANCED 3						
		ADVANCED 4						
2	Protocol	DMX						
		Artnet						
		sACN						
		Artnet+DMX						
		sACN+DMX						
3	Ethernet Setting	IP Address	xxx.xxx.xxx.xxx					
		Artnet Universe	0-32767					
		sACN Universe	1-63999					
		Start Address	1-512					
		Net To DMX	Off On					
4	Stand Alone	Master/Slave	Slave					
			Master					
		Color Macros	Fixed Color		R			
					G			
					B			
					W			
					GB			
					RB			
					RG			
					RW			
					GW			
					BW			
					RGB			
					RGW			
					RBW			
	GBW							
	RGBW							
Color Temperature		2800K						
		3000K						

5.2 MENU

4	Stand Alone	Color Macros		3200K			
				3500K			
				4000K			
				4500K			
				5000K			
				5600K			
				6000K			
				6500K			
				7000K			
				7500K			
				8000K			
				8500K			
				9000K			
				9500K			
				10000K			
				Manual Color	Red	0~255	
					Green	0~255	
					Blue	0~255	
				White	0~255		
			Auto Show	Show 1	Speed	1~100	
				Show 2			
				Show 3			
				Show 4			
				Show 5	Foreground	BLACK R G B W GB RB RG RW GW BW RGB RGW RBW GBW RGBW	
				Show 6			
				Show 7			
				Show 8			
				Show 9	Background		
				Show 10			
				Show 11			
				Show 12			
			...	Fade Speed	1~255		
			...				
			Show 36				
			Show 37				
			Show 38				
			...				
			Show 108				
		5	Settings	Dimmer Setting	Dimmer Mode	Off	
						Dimmer 1	
Dimmer 2							
Dimmer 3							
Dimmer Curve	Auto						
	S Curve						
	Linear						
	Square						
	Inverse Square						
LED Setting	LED Frequency			1000Hz			
				2000Hz			
				4000Hz			
				6000Hz			
		25KHz					
	Invert Mapping	No					
	Yes						

5.3 MENU

5	Settings	Fan Mode	Auto				
			On				
			Off				
			Silent				
		Display Setting	Back Light	30S			
				On			
			Flip Display	No			
				Yes			
				Auto			
		Key Lock	No				
			Yes				
		DMX FAULT	HOLD				
			BLACKOUT				
STAND ALONE							
EMERGENCY							
6	Advanced	Code:xxx	Color Calibration	Off			
				User Calibration	Red	125-255	
					Green	125-255	
					Blue	125-255	
			White		125-255		
Factory Reset	No						
	Yes						
7	Information	Fixture Hours	0~65535H				
		Led Hours	0~65535H				
		Version	DISP-V1.x				
			DRV-V1.x				
		Temperature	LED1: 40°C				
						
			LED12: 40°C				
		Fan Speed	xxx%				
		UID:	*****				
		Error Infomation					

6. INSTALLATION

6.1 Installation instructions and precautions

6.1.1 Installation instruction

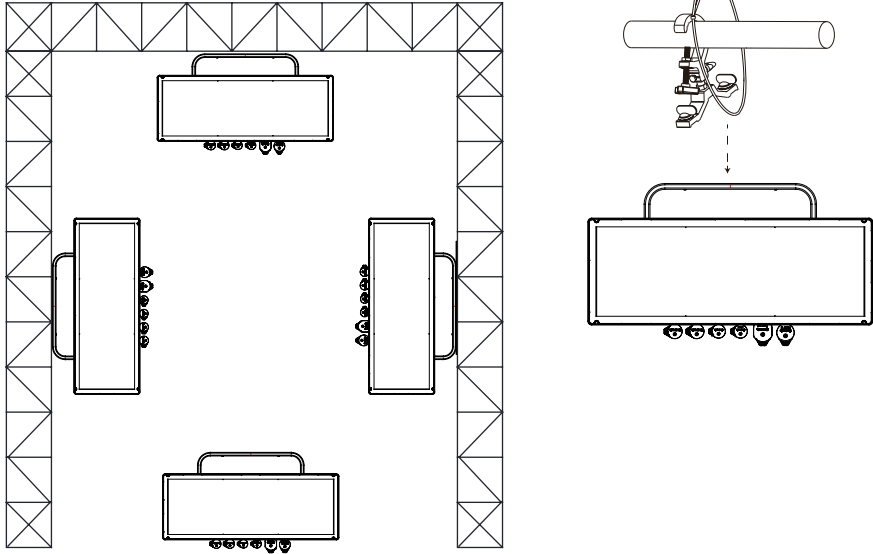

1. Professional installation required. Mount away from walkways, seating areas, or unauthorized access.
2. Never stand directly beneath the fixture during assembly, disassembly, or maintenance.
3. Ensure secure mounting to prevent vibration or slippage during operation.
4. The supporting structure must withstand 10x the fixture's weight without deformation. Always use a safety cable rated for 12x the fixture's weight to prevent falls if the clamp fails.
5. Operational in 3 positions: Sit-flat floor mounting, vertically hanging or horizontal mounting.
6. Radiant 3000+ is IP66 (indoor & Outdoor use), ensuring: Dustproof – Prevents significant dust ingress, so that it will not interfere with its normal operation. Water-resistant – Protects against water jets from any direction.

FLOWN MOUNTING

1. When installing the device, be sure to keep it away from flammable items (decorative materials, etc.), keeping a distance of at least 0.5 meters.
2. When hanging, be sure to install a safety rope with a load-bearing capacity of at least 10 times the weight of the lamp.
3. When hanging, the device for fixing the lamp must use a mounting bracket that can bear at least 10 times the weight of the lamp.
4. As shown in the figure, the safety rope needs to pass through the safety rope hole of the lamp and the mounting bracket to ensure that the structure connected to the lamp is firm.

6.2 Power Connection

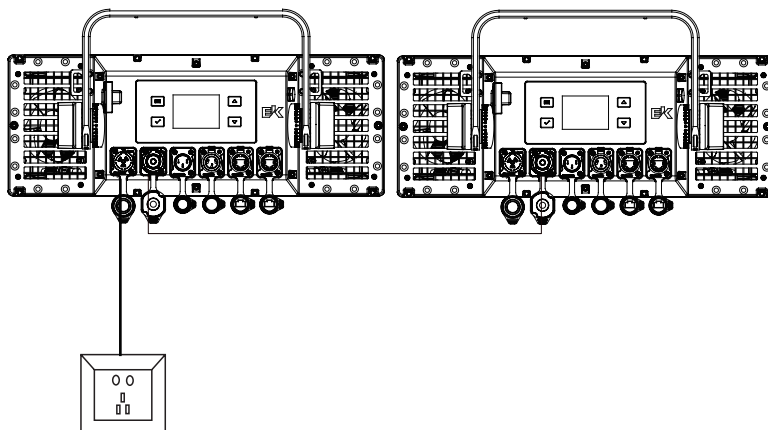

Power connection instructions

Notes: For power reasons, using 1.5mm² power cable can link up to 2 units(230V) maximum.



Warning

- Do not connect too many lamps to a single power cord or overload it.
- Do not use a power cord with damaged insulation, and do not place the power cord over other wires.
- When the lamp is not in use or is being cleaned, please unplug the power cord.
- Do not pull the power cord with force or pull it directly.

6.3 SIGNAL CONNECTION

Network connection

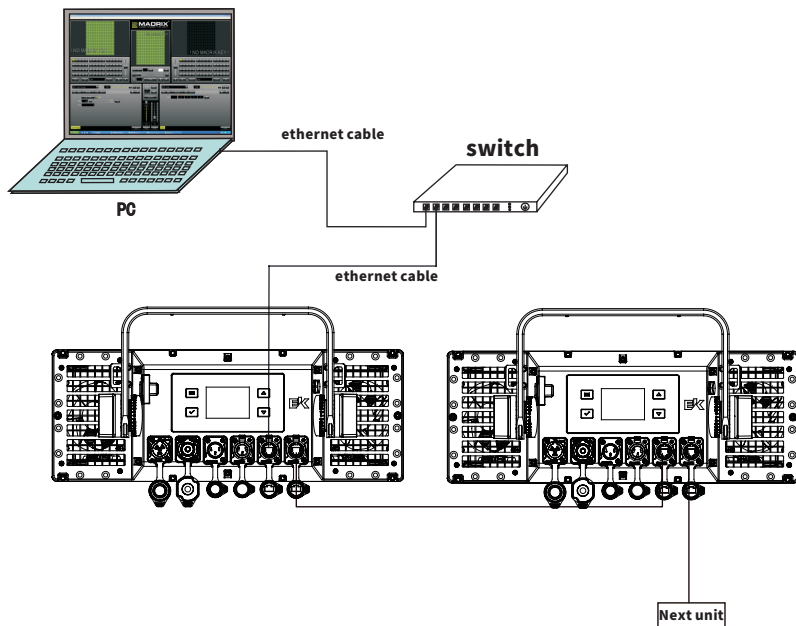

DMX Connection

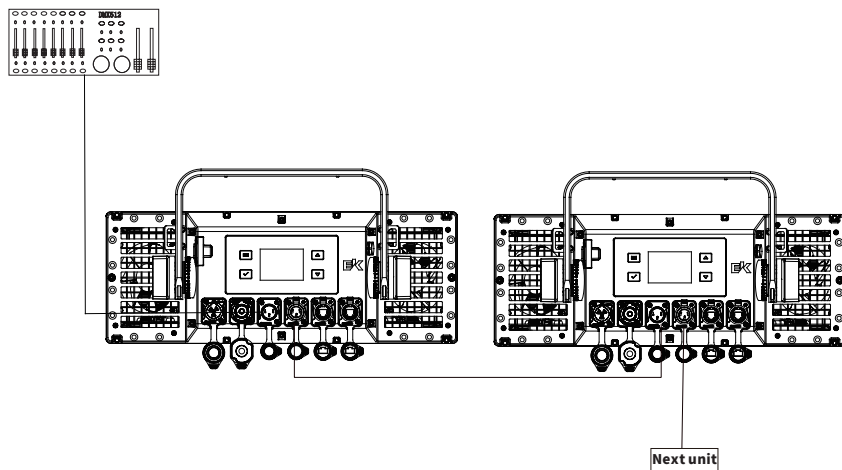

DMX CONNECTION INSTRUCTIONS

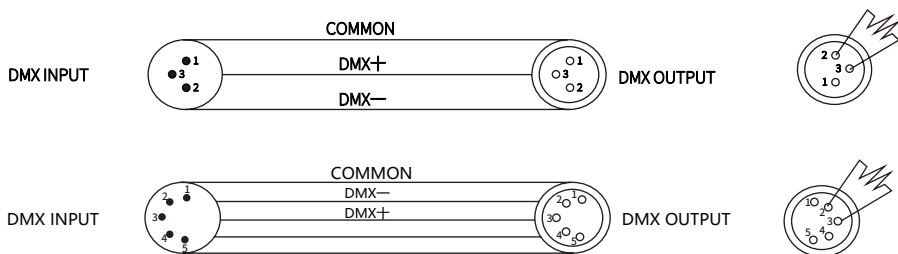

- In order to reduce signal errors and avoid signal attenuation and interference during transmission, you can add a 120 ohm 1/4W resistor between the 2nd and 3rd pins of the DMX output terminal of the last machine.
- Connect the fixtures with XLR cables, connecting one end to the output port of one fixture and the other end to the input port of the next fixture. Cables should only be used in series, not in parallel. Because DMX512 signals transmit very quickly, damage to the cable, loose solder joints, or poor contact can affect signal transmission and cause the system to shut down.
- When the power supply of a unit is cut off, the DMX output and input connections are bypassed to maintain the connectivity of the DMX line.
- Each lamp must have an address code to receive information from the console.
- The terminal of the DMX512 system needs to be equipped with a terminator to reduce errors in signal transmission.

DMX Address code setting

MODE	Allocation	Address of 1st fixture	Address of 2st fixture	Address of 3st fixture
ADVANCED 1	001 -015	001	016	031
ADVANCED 2	001 -251	001	252	001
ADVANCED 3	001 -027	001	028	055
ADVANCED 4	001 -263	001	264	001

(Refer to the figure above) The number of lamps added after the 4th one; the address code is based on the channel, and so on.

6.4DMX CHART

BASIC 5CH - STATIC				
Channel	Function	Value	Percent/Setting	Remark
1	Red	000-255	Red intensity	
2	Green	000-255	Green intensity	
3	Blue	000-255	Blue intensity	
4	White	000-255	White intensity	
5	CONTROL (Hold 3 Second)	000-005	None	
		006-010	Dimmer Mode Off	
		011-015	Dimmer Mode 1	
		016-020	Dimmer Mode 2	
		021-025	Dimmer Mode 3	
		026-030	Dimmer Mode Auto	
		031-035	Dimmer curve S	
		036-040	Dimmer curve Linear	
		041-045	Dimmer curve Square	
		046-050	Dimmer curve Inverse Square	
		051-055	Led Frequency=1000Hz	
		056-060	Led Frequency=2000Hz	
		061-065	Led Frequency=4000Hz	
		066-070	Led Frequency=6000Hz	
		071-075	Led Frequency=25000Hz	
		076-080	Fan Mode Auto	
		081-085	Fan Mode On	
		086-090	Fan Mode Off	
		091-095	Fan Mode Silent	
		096-100	RESERVED	
101-105	Invert Mapping Off			
106-110	Invert Mapping On			
111-250	RESERVED			
251-255	Complete Reset			
BASIC 6CH- STROBE (color could be choosed by menu)				
Channel	Function	Value	Percent/Setting	Remark
1	DIMMER	000-255	Minimum to maximum	
2	DIMMER FINE	000-255	Minimum to maximum	
3	FLASH DURATION	000-255	15ms-990ms	
4	FLASH RATE	000-010	No Flash	
		011-255	Strobe slow to fast	
5	FLASH FX	000-002	No Effect	
		003-005	Static	If selected, the fixture will work as wash, only dimmer control.
		006-042	Ramp up	
		043-085	Ramp down	
		086-128	Ramp up-down	
		129-171	Random	
		172-214	Lightning	
		215-255	Spikes	
6	CONTROL (Hold 3 Second)	000-005	None	
		006-010	Dimmer Mode Off	
		011-015	Dimmer Mode 1	
		016-020	Dimmer Mode 2	
		021-025	Dimmer Mode 3	
		026-030	Dimmer Mode Auto	
		031-035	Dimmer curve S	
		036-040	Dimmer curve Linear	
		041-045	Dimmer curve Square	
		046-050	Dimmer curve Inverse Square	

6.4.2 DMX Chart

		051-055	Led Frequency=1000Hz	
		056-060	Led Frequency=2000Hz	
		061-065	Led Frequency=4000Hz	
		066-070	Led Frequency=6000Hz	
		071-075	Led Frequency=25000Hz	
		076-080	Fan Mode Auto	
		081-085	Fan Mode On	
		086-090	Fan Mode Off	
		091-095	Fan Mode Silent	
		096-100	RESERVED	
		101-105	Invert Mapping Off	
		106-110	Invert Mapping On	
		111-250	RESERVED	
		251-255	Complete Reset	
BASIC 241CH- PIXEL				
Channel	Function	Value	Percent/Setting	Remark
1	PIXEL 1 RED	000-255	Red intensity	
2	PIXEL 1 GREEN	000-255	Green intensity	
3	PIXEL 1 BLUE	000-255	Blue intensity	
4	PIXEL 1 WHITE	000-255	White intensity	
	...			
237	PIXEL 60 RED	000-255	Red intensity	
238	PIXEL 60 GREEN	000-255	Green intensity	
239	PIXEL 60 BLUE	000-255	Blue intensity	
240	PIXEL 60 WHITE	000-255	White intensity	
241	CONTROL (Hold 3 Second)	000-005	None	
		006-010	Dimmer Mode Off	
		011-015	Dimmer Mode 1	
		016-020	Dimmer Mode 2	
		021-025	Dimmer Mode 3	
		026-030	Dimmer Mode Auto	
		031-035	Dimmer curve S	
		036-040	Dimmer curve Linear	
		041-045	Dimmer curve Square	
		046-050	Dimmer curve Inverse Square	
		051-055	Led Frequency=1000Hz	
		056-060	Led Frequency=2000Hz	
		061-065	Led Frequency=4000Hz	
		066-070	Led Frequency=6000Hz	
		071-075	Led Frequency=25000Hz	
		076-080	Fan Mode Auto	
		081-085	Fan Mode On	
		086-090	Fan Mode Off	
		091-095	Fan Mode Silent	
		096-100	RESERVED	
		101-105	Invert Mapping Off	
106-110	Invert Mapping On			
111-250	RESERVED			
251-255	Complete Reset			
BASIC 13CH- RGBW STROBE				
Channel	Function	Value	Percent/Setting	Remark
1	RED	000-255	Red intensity	
2	GREEN	000-255	Green intensity	
3	BLUE	000-255	Blue intensity	
4	WHITE	000-255	White intensity	

6.4.3 DMX Chart

5	CCT	000-255	Color Temperature	
6	TINT	000-255		
7	CROSSFADE	000-255		
8	DIMMER	000-255	Minimum to maximum	
9	DIMMER FINE	000-255	Minimum to maximum	
10	FLASH DURATION	000-255	15ms-990ms	
11	FLASH RATE	000-010	No Flash	
		011-255	Strobe slow to fast	
		000-002	No Effect	
12	FLASH FX	003-005	Static	If selected, works as wash, only dimmer and color control.
		006-042	Ramp up	
		043-085	Ramp down	
		086-128	Ramp up-down	
		129-171	Random	
		172-214	Lightning	
		215-255	Spikes	
		000-005	None	
13	CONTROL (Hold 3 Second)	006-010	Dimmer Mode Off	
		011-015	Dimmer Mode 1	
		016-020	Dimmer Mode 2	
		021-025	Dimmer Mode 3	
		026-030	Dimmer Mode Auto	
		031-035	Dimmer curve S	
		036-040	Dimmer curve Linear	
		041-045	Dimmer curve Square	
		046-050	Dimmer curve Inverse Square	
		051-055	Led Frequency=1000Hz	
		056-060	Led Frequency=2000Hz	
		061-065	Led Frequency=4000Hz	
		066-070	Led Frequency=6000Hz	
		071-075	Led Frequency=25000Hz	
		076-080	Fan Mode Auto	
		081-085	Fan Mode On	
		086-090	Fan Mode Off	
		091-095	Fan Mode Silent	
		096-100	RESERVED	
		101-105	Invert Mapping Off	
		106-110	Invert Mapping On	
		111-250	RESERVED	
		251-255	Complete Reset	

PIXELS - PIXELS							
PIXEL MODE	DMX Artnet	Art-net+DMX Artnet		Function	Value	Percent/Setting	Remark
	1	/	1	DIMMER	000-255	Minimum to maximum	
	2	/	2	DIMMER FINE	000-255	Minimum to maximum	
	3	/	3	FLASH DURATION	000-255	15ms-990ms	
	4	/	4	FLASH RATE	000-010	No Flash	Single flash with ch 1
					011-255	Strobe slow to fast	

6.4.4DMX Chart

5	/	5	FLASH FX	000-002	No Effect	If selected, the fixture will work as wash, only dimmer control.				
				003-005	Static					
				006-042	Ramp up					
				043-085	Ramp down					
				086-128	Ramp up-down					
				129-171	Random					
				172-214	Lightning					
				215-255	Spikes					
				6	/		6	CCT	000-255	Color Temperature
				7	/		7	TINT	000-255	
				8	/		8	CROSSFADE	000-255	
				9	/		9	CONTROL(Hold 3 Second)	000-005	None
									006-010	Dimmer Mode Off
									011-015	Dimmer Mode 1
016-020	Dimmer Mode 2									
021-025	Dimmer Mode 3									
026-030	Dimmer Mode Auto									
031-035	Dimmer curve S									
036-040	Dimmer curve Linear									
041-045	Dimmer curve Square									
046-050	Dimmer curve Inverse Square									
051-055	Led Frequency=1000Hz									
056-060	Led Frequency=2000Hz									
061-065	Led Frequency=4000Hz									
066-070	Led Frequency=6000Hz									
071-075	Led Frequency=25000Hz									
076-080	Fan Mode Auto									
081-085	Fan Mode On									
086-090	Fan Mode Off									
091-095	Fan Mode Silent									
096-100	RESERVED									
101-105	Invert Mapping Off									
106-110	Invert Mapping On									
111-250	RESERVED									
251-255	Complete Reset									
1	10	1	/	PIXEL 1	RED	000-255	Red intensity	Pixel Mapping		
	11	2	/		GREEN	000-255	Green intensity			
	12	3	/		BLUE	000-255	Blue intensity			
	13	4	/		WHITE	000-255	White intensity			
3	14	5	/	PIXEL 3	RED	000-255	Red intensity			
	15	6	/		GREEN	000-255	Green intensity			
	16	7	/		BLUE	000-255	Blue intensity			
	17	8	/		WHITE	000-255	White intensity			
	18	9	/		RED	000-255	Red intensity			
	19	10	/		GREEN	000-255	Green intensity			
	20	11	/		BLUE	000-255	Blue intensity			
	21	12	/		WHITE	000-255	White intensity			

6.4.5 DMX Chart

4	22	13	/	PIXEL 4	RED	000-255	Red intensity
	23	14	/		GREEN	000-255	Green intensity
	24	15	/		BLUE	000-255	Blue intensity
	25	16	/		WHITE	000-255	White intensity
5	26	17	/	PIXEL 5	RED	000-255	Red intensity
	27	18	/		GREEN	000-255	Green intensity
	28	19	/		BLUE	000-255	Blue intensity
	29	20	/		WHITE	000-255	White intensity
6	30	21	/	PIXEL 6	RED	000-255	Red intensity
	31	22	/		GREEN	000-255	Green intensity
	32	23	/		BLUE	000-255	Blue intensity
	33	24	/		WHITE	000-255	White intensity
...	...						
12	54	45	/	PIXEL 12	RED	000-255	Red intensity
	55	46	/		GREEN	000-255	Green intensity
	56	47	/		BLUE	000-255	Blue intensity
	57	48	/		WHITE	000-255	White intensity
...	...						
18	78	69	/	PIXEL 18	RED	000-255	Red intensity
	79	70	/		GREEN	000-255	Green intensity
	80	71	/		BLUE	000-255	Blue intensity
	81	72	/		WHITE	000-255	White intensity
...	...						
30	126	117	/	PIXEL 30	RED	000-255	Red intensity
	127	118	/		GREEN	000-255	Green intensity
	128	119	/		BLUE	000-255	Blue intensity
	129	120	/		WHITE	000-255	White intensity
...	...						
36	150	141	/	PIXEL 36	RED	000-255	Red intensity
	151	142	/		GREEN	000-255	Green intensity
	152	143	/		BLUE	000-255	Blue intensity
	153	144	/		WHITE	000-255	White intensity
...	
60	246	237	/	PIXEL 60	RED	000-255	Red intensity
	247	238	/		GREEN	000-255	Green intensity
	248	239	/		BLUE	000-255	Blue intensity
	249	240	/		WHITE	000-255	White intensity

ADVANCED:

1. Background could be shining only when the foreground is strobing or running an effect.
2. In case both the foreground and background are shining simultaneously, then foreground takes precedence over the background.
3. In case both the first and second layer effects are active simultaneously, the second layer takes precedence.
4. In case the foreground and Layer 1 use the same color, Layer 1 takes precedence. only when Layer 1 does not control the color, then foreground and background can be overlaid. (ADVANCED 3/4)

ADVANCED - ADVANCED 1

Channel	Function	Value	Percent/Setting	Remark
1	DIMMER	000-255	Minimum to maximum	
2	DIMMER FINE	000-255	Minimum to maximum	
3	FLASH DIMMER	000-255	Strobe dimmer	
4	FLASH STROBE	000-030	No flash/Closed	
		031-100	Strobe slow to fast	
		101-130	Open	
		131-200	Random strobe slow to fast	
		201-255	Open	
5	FLASH RED	000-255	Red intensity	
6	FLASH GREEN	000-255	Green intensity	

6.4.6 DMX Chart

7	FLASH BLUE	000-255	Blue intensity	
8	FLASH WHITE	000-255	White intensity	
9	CCT	000-255	Color Temperature	
10	TINT	000-255		
11	CROSSFADE	000-255		
12	BG DIMMER	000-255	Strobe Dimmer	The background can light up only when foreground strobes or runs performance.
13	BG STROBE	000-030	No flash/Closed	
		031-100	Strobe slow to fast	
		101-130	Open	
		131-200	Random strobe slow to fast	
		201-255	Open	
14	BG RED	000-255	Red intensity	
15	BG GREEN	000-255	Green intensity	
16	BG BLUE	000-255	Blue intensity	
17	BG WHITE	000-255	White intensity	
18	AUTO FX	000-010	No Function	
		011-012	FX 1	
		013-014	FX 2	
		015-016	FX 3	
		017-018	FX 4	
		019-020	FX 5	
		021-022	FX 6	
		023-024	FX 7	
		025-026	FX 8	
		027-028	FX 9	
		029-030	FX 10	
		031-032	FX 11	
		033-034	FX 12	
		035-036	FX 13	
		037-038	FX 14	
		039-040	FX 15	
		
		079-080	FX 35	
		081-082	FX 36	
		083-132	Random pixel(with density)	From 1 to 10 pixel, 1 more pixel every 5 steps
		133	FX 37	
		134	FX 38	
		135	FX 39	
...	...			
202	FX 106			
203	FX 107			
204	FX 108			
205-255	RESERVED(TBD)			
19	FX SPEED	000-050	Static indexing	
		051-255	From slow to fast	
20	FX FADE	000-255		

6.4.7 DMX Chart

21	CONTROL(Hold 3 Second)	000-005	None	
		006-010	Dimmer Mode Off	
		011-015	Dimmer Mode 1	
		016-020	Dimmer Mode 2	
		021-025	Dimmer Mode 3	
		026-030	Dimmer Mode Auto	
		031-035	Dimmer curve S	
		036-040	Dimmer curve Linear	
		041-045	Dimmer curve Square	
		046-050	Dimmer curve Inverse Square	
		051-055	Led Frequency=1000Hz	
		056-060	Led Frequency=2000Hz	
		061-065	Led Frequency=4000Hz	
		066-070	Led Frequency=6000Hz	
		071-075	Led Frequency=25000Hz	
		076-080	Fan Mode Auto	
		081-085	Fan Mode On	
		086-090	Fan Mode Off	
		091-095	Fan Mode Silent	
		096-100	RESERVED	
		101-105	Invert Mapping Off	
		106-110	Invert Mapping On	
		111-250	RESERVED	
251-255	Complete Reset			

ADVANCED - ADVANCED 2						
DMX	Art-net+DMX		Function	Value	Percent/Setting	Remark
Artnet	Artnet	DMX				
1	/	1	DIMMER	000-255	Minimum to maximum	
2	/	2	DIMMER FINE	000-255	Minimum to maximum	
3	/	3	FLASH DIMMER	000-255	0-100%	
4	/	4	FLASH STROBE	000-030	No flash/Closed	
				031-100	Strobe slow to fast	
				101-130	Open	
				131-200	Random strobe slow to fast	
				201-255	Open	
5	/	5	BG DIMMER	000-255	Strobe Dimmer	
6	/	6	BG STROBE	000-030	No flash/Closed	
				031-100	Strobe slow to fast	
				101-130	Open	
				131-200	Random strobe slow to fast	
				201-255	Open	
7	/	7	BG RED	000-255	Red intensity	
8	/	8	BG GREEN	000-255	Green intensity	
9	/	9	BG BLUE	000-255	Blue intensity	
10	/	10	BG WHITE	000-255	White intensity	

6.4.8 DMX Chart

11	/	11	AUTO FX	000-010	No Function	
				011-012	FX 1	
				013-014	FX 2	
				015-016	FX 3	
				017-018	FX 4	
				019-020	FX 5	
				021-022	FX 6	
				023-024	FX 7	
				025-026	FX 8	
				027-028	FX 9	
				029-030	FX 10	
				031-032	FX 11	
				033-034	FX 12	
				035-036	FX 13	
				037-038	FX 14	
				039-040	FX 15	
				
				079-080	FX 35	
				081-082	FX 36	
				083-132	Random pixel(with density)	From 1 to 10 pixel, 1 more pixel every 5 steps
				133	FX 37	
134	FX 38					
135	FX 39					
...	...					
202	FX 106					
203	FX 107					
204	FX 108					
205-255	RESERVED(TBD)					
12	/	12	FX SPEED	000-050	Static indexing	
				051-255	From slow to fast	
13	/	13	FX FADE	000-255		
14	/	14	CONTROL (Hold 3 Second)	000-005	None	
				006-010	Dimmer Mode Off	
				011-015	Dimmer Mode 1	
				016-020	Dimmer Mode 2	
				021-025	Dimmer Mode 3	
				026-030	Dimmer Mode Auto	
				031-035	Dimmer curve S	
				036-040	Dimmer curve Linear	
				041-045	Dimmer curve Square	
				046-050	Dimmer curve Inverse Square	
				051-055	Led Frequency=1000Hz	
				056-060	Led Frequency=2000Hz	
				061-065	Led Frequency=4000Hz	
				066-070	Led Frequency=6000Hz	
				071-075	Led Frequency=25000Hz	
				076-080	Fan Mode Auto	
				081-085	Fan Mode On	
				086-090	Fan Mode Off	
				091-095	Fan Mode Silent	
				096-100	RESERVED	
				101-105	Invert Mapping Off	
106-110	Invert Mapping On					
111-250	RESERVED					
251-255	Complete Reset					

6.4.9 DMX Chart

15	/	15	CCT	000-255	Color Temperature	
16	/	16	TINT	000-255		
17		17	CROSSFADE	000-255		
18	1	/	PIXEL 1 RED	000-255	Red intensity	
19	2	/	PIXEL 1 GREEN	000-255	Green intensity	
20	3	/	PIXEL 1 BLUE	000-255	Blue intensity	
21	4	/	PIXEL 1 WHITE	000-255	White intensity	
...	...	/	
254	237	/	PIXEL 60 RED	000-255	Red intensity	
255	238	/	PIXEL 60 GREEN	000-255	Green intensity	
256	239	/	PIXEL 60 BLUE	000-255	Blue intensity	
257	240	/	PIXEL 60 WHITE	000-255	White intensity	

ADVANCED - ADVANCED 3						
Channel	BASIC FUNCTION	FUNCTION WITH L2 FX	Value	Setting	WITH FX	Remark
1	DIMMER		000-255	Minimum to maximum		
2	DIMMER FINE		000-255	Minimum to maximum		
3	FLASH DIMMER	LAYER2 DIMMER	000-255	0-100%	Layer 2 dimmer	
4	FLASH STROBE	LAYER2 STROBE	000-030	No flash/ Closed	- Same	No output - Single flash with ch 1
			031-100	Strobe slow to fast	- Same	
			101-130	Open	- Same	
			131-200	Random strobe slow to fast	- Same	
			201-255	Open	- Same	
5	FLASH RED	LAYER2 RED	000-255	Red intensity	Layer 2 Red	
6	FLASH GREEN	LAYER2 GREEN	000-255	Green intensity	Layer 2 Green	
7	FLASH BLUE	LAYER2 BLUE	000-255	Blue intensity	Layer 2 Blue	
8	FLASH WHITE	LAYER2 WHITE	000-255	White intensity	Layer 2 White	
9	CCT		000-255	Color Temperature		
10	TINT		000-255			
11	CROSSFADE		000-255			
12	BG DIMMER		000-255	Strobe Dimmer		
13	BG STROBE		000-030	No flash/Closed		
			031-100	Strobe slow to fast		
			101-130	Open		
			131-200	Random strobe slow to fast		
			201-255	Open		
14	BG RED		000-255	Red intensity		
15	BG GREEN		000-255	Green intensity		
16	BG BLUE		000-255	Blue intensity		
17	BG WHITE		000-255	White intensity		
18	LAYER1 DIMMER		000-255	Strobe Dimmer		
19	LAYER1 STROBE		000-030	No flash/Closed		
			031-100	Strobe slow to fast		
			101-130	Open		
			131-200	Random strobe slow to fast		
			201-255	Open		
20	LAYER1 RED		000-255	Red intensity		
21	LAYER1 GREEN		000-255	Green intensity		

6.4.10 DMX Chart

22	LAYER1 BLUE	000-255	Blue intensity	
23	LAYER1 WHITE	000-255	White intensity	
24	LAYER1 FX	000-010	No Function	
		011-012	FX 1	
		013-014	FX 2	
		015-016	FX 3	
		017-018	FX 4	
		019-020	FX 5	
		021-022	FX 6	
		023-024	FX 7	
		025-026	FX 8	
		027-028	FX 9	
		029-030	FX 10	
		031-032	FX 11	
		033-034	FX 12	
		035-036	FX 13	
		037-038	FX 14	
		039-040	FX 15	
		
		079-080	FX 35	
		081-082	FX 36	
			083-132	Random pixel(with density)
	133	FX 37		
	134	FX 38		
	135	FX 39		
		
	202	FX 106		
	203	FX 107		
	204	FX 108		
	205-255	RESERVED(TBD)		
25	LAYER1 FX SPEED	000-050	Static indexing	
		051-255	From slow to fast	
26	LAYER1 FX OFFSET	000 -200	Continuous start selection	Choose the step of start
		201 -255	Random distribution	Enables an internal distribution of the macro between a multitude of lights on a specific DMX line basing on their DMX starting address.
27	LAYER2 FX (Colors and strobe are controlled by FLASH channels. If no FX is selected, the FLASH channels will works as basic function.)	000-010	No Function	
		011-012	FX 1	
		013-014	FX 2	
		015-016	FX 3	
		017-018	FX 4	
		019-020	FX 5	
		021-022	FX 6	
		023-024	FX 7	
		025-026	FX 8	
		027-028	FX 9	
		029-030	FX 10	
		031-032	FX 11	
		033-034	FX 12	
		035-036	FX 13	
037-038	FX 14			

6.4.11 DMX Chart

27	LAYER2 FX (Colors and strobe are controlled by FLASH channels. If no FX is selected, the FLASH channels will work as basic function.)	039-040	FX 15	
		
		079-080	FX 35	
		081-082	FX 36	
		083-132	Random pixel(with density)	From 1 to 10 pixel, 1 more pixel every 5 steps
		133	FX 37	
		134	FX 38	
		135	FX 39	
		
		202	FX 106	
		203	FX 107	
204	FX 108			
205-255	RESERVED(TBD)			
28	LAYER2 FX SPEED	000-050	Static indexing	
		051-255	From slow to fast	
29	LAYER2 FX OFFSET	000 -200	Continuous start selection	Choose the step of start
		201 -255	Random distribution	Enables an internal distribution of the macro between a multitude of lights on a specific DMX line basing on their DMX starting address.
30	FX FADE	000-255		
31	EMPTY	-	TBD	
32	EMPTY	-	TBD	
33	CONTROL(Hold 3 Second)	000-005	None	
		006-010	Dimmer Mode Off	
		011-015	Dimmer Mode 1	
		016-020	Dimmer Mode 2	
		021-025	Dimmer Mode 3	
		026-030	Dimmer Mode Auto	
		031-035	Dimmer curve S	
		036-040	Dimmer curve Linear	
		041-045	Dimmer curve Square	
		046-050	Dimmer curve Inverse Square	
		051-055	Led Frequency=1000Hz	
		056-060	Led Frequency=2000Hz	
		061-065	Led Frequency=4000Hz	
		066-070	Led Frequency=6000Hz	
		071-075	Led Frequency=25000Hz	
		076-080	Fan Mode Auto	
		081-085	Fan Mode On	
		086-090	Fan Mode Off	
		091-095	Fan Mode Silent	
		096-100	RESERVED	
		101-105	Invert Mapping Off	
106-110	Invert Mapping On			
111-250	RESERVED			
251-255	Complete Reset			

6.4.12 DMX Chart

ADVANCED - ADVANCED 4								
Artnet DMX	Artnet	DMX	BASIC Function	WITH L2 FX	Value	Setting	WITH FX	Remark
1	/	1	DIMMER		000-255	Minimum to maximum		
2	/	2	DIMMER FINE		000-255	Minimum to maximum		
3	/	3	FLASH DIMMER	LAYER2 DIMMER	000-255	0-100%	Layer 2 dimmer	
4	/	4	FLASH STROBE	LAYER2 STROBE	000-030	No flash/ Closed	- Same -	
					031-100	Strobe slow to fast	- Same -	
					101-130	Open	- Same -	
					131-200	Random strobe slow to fast	- Same -	
				201-255	Open	- Same -		
5	1	/	FLASH 1 RED	LAYER2 1 RED	000-255	Red intensity	Layer 2 Red	
6	2	/	FLASH 1 GREEN	LAYER2 1 GREEN	000-255	Green intensity	Layer 2 Green	
7	3	/	FLASH 1 BLUE	LAYER2 1 BLUE	000-255	Blue intensity	Layer 2 Blue	
8	4	/	FLASH 1 WHITE	LAYER2 1 WHITE	000-255	White intensity	Layer 2 White	
..	..	/		
241	237	/	FLASH 60 RED	LAYER2 60 RED	000-255	Red intensity	Layer 2 Red	
242	238	/	FLASH 60 GREEN	LAYER2 60 GREEN	000-255	Green intensity	Layer 2 Green	
243	239	/	FLASH 60 BLUE	LAYER2 60 BLUE	000-255	Blue intensity	Layer 2 Blue	
244	240	/	FLASH 60 WHITE	LAYER2 60 WHITE	000-255	White intensity	Layer 2 White	
245	/	5	CCT		000-255	Color Temperature		
246		6	TINT		000-255			
247	/	7	CROSSFADE		000-255			
248	/	8	BG DIMMER		000-255	Strobe Dimmer		
249	/	9	BG STROBE		000-030	No flash/Closed		
					031-100	Strobe slow to fast		
					101-130	Open		
					131-200	Random strobe slow to fast		
				201-255	Open			
250	/	10	BG RED		000-255	Red intensity		
251	/	11	BG GREEN		000-255	Green intensity		
252	/	12	BG BLUE		000-255	Blue intensity		
253		13	BG WHITE		000-255	White intensity		
254	/	14	LAYER1 DIMMER		000-255	Strobe Dimmer		
255	/	15	LAYER1 STROBE		000-030	No flash/Closed		
					031-100	Strobe slow to fast		
					101-130	Open		
					131-200	Random strobe slow to fast		
				201-255	Open			
256	/	16	LAYER1 RED		000-255	Red intensity		
257	/	17	LAYER1 GREEN		000-255	Green intensity		
258	/	18	LAYER1 BLUE		000-255	Blue intensity		
259	/	19	LAYER1 WHITE		000-255	White intensity		

6.4.13 DMX Chart

260	/	20	LAYER1 FX	000-010	No Function	
				011-012	FX 1	
				013-014	FX 2	
				015-016	FX 3	
				017-018	FX 4	
				019-020	FX 5	
				021-022	FX 6	
				023-024	FX 7	
				025-026	FX 8	
				027-028	FX 9	
				029-030	FX 10	
				031-032	FX 11	
				033-034	FX 12	
				035-036	FX 13	
				037-038	FX 14	
				039-040	FX 15	
				
				079-080	FX 35	
				081-082	FX 36	
				083-132	Random pixel(with density)	From 1 to 10 pixel, 1 more pixel every 5 steps
133	FX 37					
134	FX 38					
135	FX 39					
...	...					
202	FX 106					
203	FX 107					
204	FX 108					
205-255	RESERVED(TBD)					
261	/	21	LAYER1 FX SPEED	000-050	Static indexing	
				051-255	From slow to fast	
262	/	22	LAYER1 FX OFFSET	000-200	Continuous start selection	Choose the step of start
				201-255	Random distribution	Enables an internal distribution of the macro between a multitude of lights on a specific DMX line basing on their DMX starting address.
263	/	23	LAYER2 FX (Colors and strobe are controlled by FLASH channels. If no FX is selected, the FLASH channels will works as basic function.)	000-010	No Function	
				011-012	FX 1	
				013-014	FX 2	
				015-016	FX 3	
				017-018	FX 4	
				019-020	FX 5	
				021-022	FX 6	
				023-024	FX 7	
				025-026	FX 8	
				027-028	FX 9	
				029-030	FX 10	
				031-032	FX 11	
				033-034	FX 12	
				035-036	FX 13	
				037-038	FX 14	
				039-040	FX 15	
				
079-080	FX 35					

6.4.14 DMX Chart

				081-082	FX 36	
				083-132	Random pixel(with density)	From 1 to 10 pixel, 1 more pixel every 5 steps
				133	FX 37	
				134	FX 38	
				135	FX 39	
				
				202	FX 106	
				203	FX 107	
				204	FX 108	
				205-255	RESERVED(TBD)	
264	/	24	LAYER2 FX SPEED	000-050	Static indexing	
				051-255	From slow to fast	
265	/	25	LAYER2 FX OFFSET	000 -200	Continuous start selection	Choose the step of start
				201 -255	Random distribution	Enables an internal distribution of the macro between a multitude of lights on a specific DMX line basing on their DMX starting address.
266		26	FX FADE	000-255		
267	/	27	EMPTY	-	TBD	
268	/	28	EMPTY	-	TBD	
269	/	29	CONTROL(Hold 3 Second)	000-005	None	
				006-010	Dimmer Mode Off	
				011-015	Dimmer Mode 1	
				016-020	Dimmer Mode 2	
				021-025	Dimmer Mode 3	
				026-030	Dimmer Mode Auto	
				031-035	Dimmer curve S	
				036-040	Dimmer curve Linear	
				041-045	Dimmer curve Square	
				046-050	Dimmer curve Inverse Square	
				051-055	Led Frequency=1000Hz	
				056-060	Led Frequency=2000Hz	
				061-065	Led Frequency=4000Hz	
				066-070	Led Frequency=6000Hz	
				071-075	Led Frequency=25000Hz	
				076-080	Fan Mode Auto	
				081-085	Fan Mode On	
				086-090	Fan Mode Off	
				091-095	Fan Mode Silent	
				096-100	RESERVED	
				101-105	Invert Mapping Off	
				106-110	Invert Mapping On	
				111-250	RESERVED	
				251-255	Complete Reset	

7.TROUBLESHOOTING

TROUBLESHOOTING		
Problems	Possible Causes	Checks and Remedles
Fixture does not power up	<ol style="list-style-type: none"> 1. Fuse is blown 2. The power supply has no voltage input or output 3. Power socket damaged 	<ol style="list-style-type: none"> 1. Replace fuse with the same specification 2. Replace power supply unit 3. Replace power socket
Unable to receive DMX signal	<ol style="list-style-type: none"> 1. DMX signal port damaged 2. Abnormal main board 3. DMX signal cable is broken 4. The DMX address code setting of fixture does not match console 	<ol style="list-style-type: none"> 1. Replace DMX port 2. Replace main PCB 3. Replace signal cable 4. Check and reset the DMX address code
Light spot deviate, out of focus, insufficient brightness	<ol style="list-style-type: none"> 1. Optical components is loosen 2. The light bulb is not installed properly 3. Dirty lens 	<ol style="list-style-type: none"> 1. Tighten optical components 2. Recalibrate the concentricity of the light bulb 3. Clean optical components
Overheating, automatic protection	<ol style="list-style-type: none"> 1. Fan damaged 2. Blockage of air outlet 3. Abnormal driver PCB 	<ol style="list-style-type: none"> 1. Replace fan 2. Clear the air outlet 3. Replace driver PCB
The light source does not work/ the bulb fails to light (non professionals are prohibited to measure light bulbs/ ballasts/ power supply)	<ol style="list-style-type: none"> 1. Light bulb damaged 2. Light bulb starter malfunction 3. Power supply has no voltage output 4. Abnormal LED driver PCB 	<ol style="list-style-type: none"> 1. Replace light bulb 2. Replace bulb starter 3. Replace power supply 4. Replace LED driver PCB

8. MAINTENANCE AND CARE

- 1.Regular cleaning is very important to life and performance of lamp. The accumulation of dust, dirt, smoke particles, atomized liquid residue, etc. will reduce the light output and heat dissipation ability of lamp.
- 2.The cleaning time of lamps varies greatly depending on the operating environment, so it is impossible to specify a precise cleaning interval for lamps.

Environmental factors that may require more frequent cleaning include:

Use a fogger or mist machine.

High air flow rates (for example, near air conditioning vents).

Airborne dust (e.g. from stage effects, building structures and decorations, or the natural environment at outdoor events).

If one or more of these factors are present, check the fixture for cleaning needs within the first few hours of operation. Continue checking the fixture frequently thereafter. This process will enable you to assess the need for cleaning in your specific situation.

When cleaning lamps, pay attention to the following points:

Do this in a clean, dry, well-lit area.

Only wipe gently. We recommend using a soft, lint-free cloth with water or a mild detergent solution. Do not use alcohol, solvents, or abrasives under any circumstances! Be extremely careful when cleaning optical components: their surfaces are fragile and easily scratched.

CLEANING PROCESS



Warning

DISCONNECT THE POWER SUPPLY BEFORE OPENING ANY COVERS

Wipe optical components gently; the coating surface is very brittle and easily scratched. Do not use aggressive solvents that may damage the plastic or coating surface.

Cleaning optics:

- 1.After power off, cool thoroughly and open the lid.
- 2.Use a vacuum cleaner or pressure blower to gently blow away dust and floating objects
- 3.Use unscented tissue paper or cotton cloth soaked in clean or distilled water to wipe off the particles. Do not wipe the surface. Use pressurized air to blow away floating objects.
- 4.Use cotton cloth soaked in ethyl propylene glycol or unscented tissue paper to remove smoke and residue. You can also use glass cleaner, but the residue must be removed with distilled water. Wipe in circles from the center to the sides, then wipe dry with a soft cotton cloth.
- 5.Clean the fan and air vents. Use a soft brush, tissue paper, air vacuum cleaner or pressure blower to remove dust from the fan and air vents.

9. PIXEL MAPPING

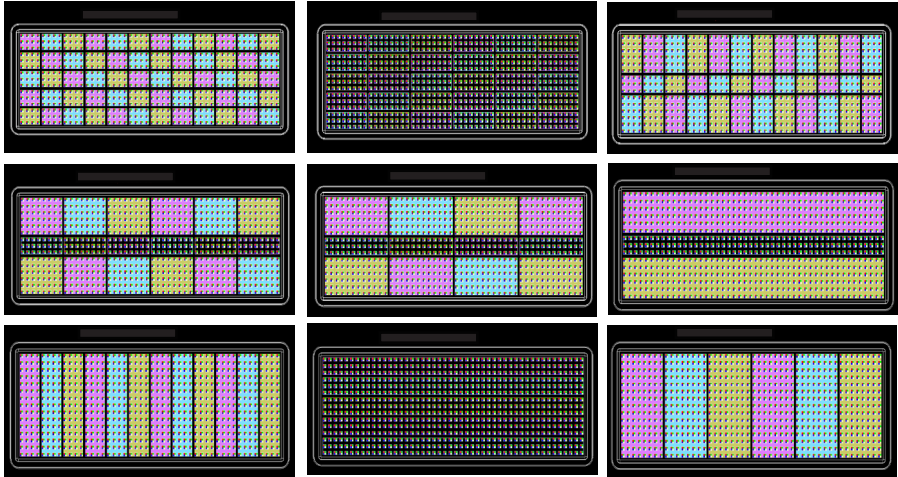

10. EXPLODED VIEW

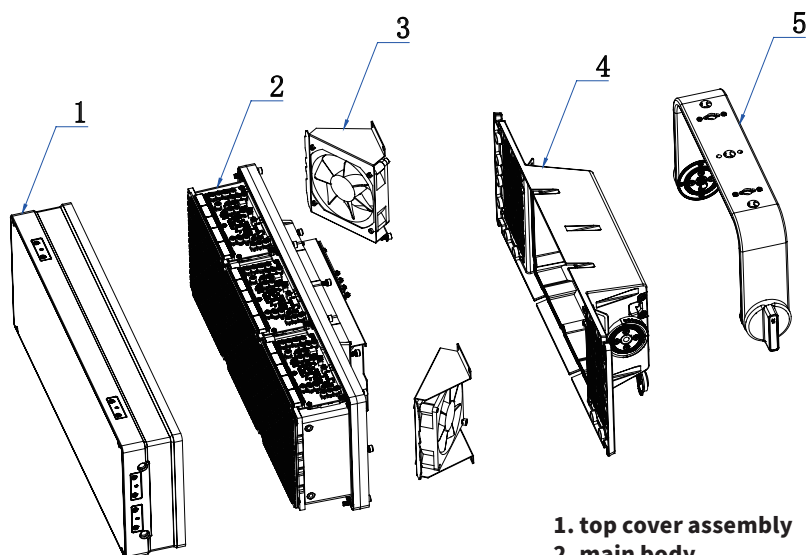

1. top cover assembly
2. main body
3. fan assembly
4. back cover assembly
5. hanging bracket assembly



EKINC.

Address: NO.55 Zhongzhun Road, Cuiheng New District, Zhongshan City, Guangdong Province

Phone: 0086 (0760) 88280099

www.eklights.com